



**DUST AND WATERPROOF
INDUSTRIAL LUMINAIRES**

2024



IBV Hungária Lighting and Plastic Processing Kft. – member of IBV Holding in Germany – was founded in 1993 in Hungary, Kiskunfélegyháza, a town with a significant industrial heritage. Thanks to its dynamic development, today our company **is one of the leading producers of dust and waterproof luminaires in Europe.**

One of our main activities is the production of **industrial luminaires with a high IP rating** developed by IBV, in addition to manufacturing GRP-based (**glass fibre reinforced polyester**) products (kitchen sinks, electric cabinets and telecommunication equipment) designed in cooperation with our partners.



We have a leading position on the international market of dust and waterproof luminaires. Our company has been recognized on the market as an **expert** in the field of plastic processing **producing excellent quality products** thanks to the vast experience acquired for more than 30 years. **More than 95% of our production volume is sold on international markets in more than 70 countries** of 5 continents.

Feedbacks from our partners on countless occasions confirm the **outstanding price/performance ratio** of our products we are able to offer thanks to two major factors: **German technology used in combination with professional know-how of Hungarian experts.**

The quality level of our products meets the requirements of **European standards (ENEC)** and the highest expectations of our customers. Our SAP integrated company management system gives framework to our activities, thus ensuring that we keep providing our customers with high-quality products. Our company's quality and environment management systems are certified and meet the requirements of the **ISO 9001** quality management system as well as the **ISO 14001** environment management system.

Briefly in figures:

Experience in lighting:	30 years
Product portfolio:	4000 product variation
Luminaires sold:	2.2 million pieces/year
GRP processing:	5500 ton/year
Number of employees:	~500
Built-up area:	35,000 m ²

**IBV Hungaria
Introduction Movie**



OUR COMPETENCIES

■ IBV Hungária Kft's quality management system guarantees that we deliver high-quality products with reliable operation. **Our products meet the European standards as well as the highest expectations of our customers.**

Since 2003 our manufacturing and supporting activities are regulated by the **ISO 9001 Quality Management System** and since 2013 also by the **ISO 14001 Environmental Management System**.



We can undertake a comprehensive quality inspection of our products during the sampling process as well as during production. **EMC** (electromagnetic compatibility), **IP** (ingress protection) and other product-specific tests are frequently run in our laboratory. Besides the basic dimensional measuring and impact resistance measuring we can inspect other product features through testing such as glow-wire, weather resistance, luminous flux and components' water absorption.

Our products comply with the requirements set forth by the relevant European standards and therefore bear the **CE sign**. Furthermore, they are also certified by independent, accredited institutes and thus they also have the **ENEC sign**.

On today's market of luminaires a producer's success is determined by the quality of its products and whether they work safely and reliably. In the light of this, our production is driven by the principle of manufacturing good quality products, which is ensured by careful scrutiny and continuous improvement of our processes from purchase of components to delivery of our products. Our luminaires are equipped exclusively with good quality components and each single piece is tested using a 100% electricity test.

■ As one of Europe's largest **GRP (glass fibre reinforced polyester)** consumers, our company processes more than 5.000 tons of raw material annually. This makes us - after the automobile industry - the continent's largest consumer of GRP.

Thanks to our plant giving place to more than **40 pressing machines** (with a pressing force from 150 to 2000 tons), we are able to manufacture products of the size of a match-box to that of the size of a cabinet.

The GRP (called also SMC) is processed in high temperature and under great pressing force in the tool where it (after about 1.5-2 minutes) solidifies. As a result, we get a product with perfect features.

Polyester belonging to the group of thermosetting plastics has great mechanical characteristics and its stability of size and shape at changing temperatures is excellent, far better than in case of other plastics (e.g. polycarbonate); additionally, it is also a good electrical insulator.

It is most widely used where there is a need for a component that is light and resistant such as in the automobile industry, aviation and ship industry and in the production of luminaires.



■ We extended our machinery portfolio with a brand new **Thermoset Injection Moulding (BMC)** machine with 200 tons of press force. On this BMC machine we are able to produce various products for the middle voltage and home appliances markets made of **Bulk Moulded Compound (BMC)** material.

■ With our **injection moulding** machines (with a pressing force from 900 up to 1200 tons) we process several hundred tons of thermoplastics annually, such as **PC** (polycarbonate), **PMMA** (polymethylmethacrylate).

With these machines we produce UV resistant diffusers designed with respect to their optical characteristics. We have vast experience in the production and handling of **transparent** as well as **opalised** thermoplastic polymers.



■ The **sealing** of our products is done with the use of a two-component **polyurethane foam** that is applied with the help of an automatized production line. This allows us to manufacture products with an IP rating of 65, 66, 67 or 69 according to the needs of our customers. Benefits of this technology include swift production and reliable quality. In addition to our three foaming machines, a fourth one has been recently installed where we use a **silicone foam** with unique features.

■ Coextrusion is a complex **extrusion process** in which the machine can extrude **two materials of different colours at the same time** (merged within the tool). Its main advantage is that the optical part of the luminaire can be clear or opalised while the back of the extruded profile can be any other colour, usually white or grey. The machine has an extrusion speed of 0.8–3 m/min – depending on the construction. The raw materials we use are **PC** or **PMMA**. In the lighting business we use it for manufacturing **extruded profiles** applied at **tubular luminaires** such as in case of our newly developed, 793-Multiproof, too. **Coextrusion offers several advantages** to our company as an exciting field of technology. New dimensions are opening in product development that are limited only by imagination. This resulted in the **expansion of our product portfolio**. We expect that the installation of the new extruder line will provide our company with **further business opportunities** and **new target markets**.



■ The assembly of our luminaires takes place in our **assembly workshop** at the highest level. The Kanban system ensures that all the necessary components are at disposal according to needs, thus contributing to an efficient assembly process. All of our assembled luminaires are **100% checked for quality and functionality**.

■ Numerous European companies have transferred the production of their plastic products to us. We have assumed our partners' production successfully whether it is GRP or thermoplastics processing. Nothing expresses the trust of our partners placed in us better than the fact that such projects resulting from production transfers account for 30% of our revenue.

We have gained great **experience in the maintenance and repair of moulds** producing plastic components, thanks to the fact that we look after our own as well as our partners' moulds. Our mould shop has all the facilities necessary account for maintaining and repairing the moulds, which helps us to provide ongoing maintenance work of several hundred moulds.

It is our extensive know-how, experience and expert knowledge acquired over the years that help us orchestrate a complex transfer of production very often requiring significant technological development – from design through sampling process to the successful realization of the project – in a professional manner ensuring our partner that the production is in safe and competent hands.

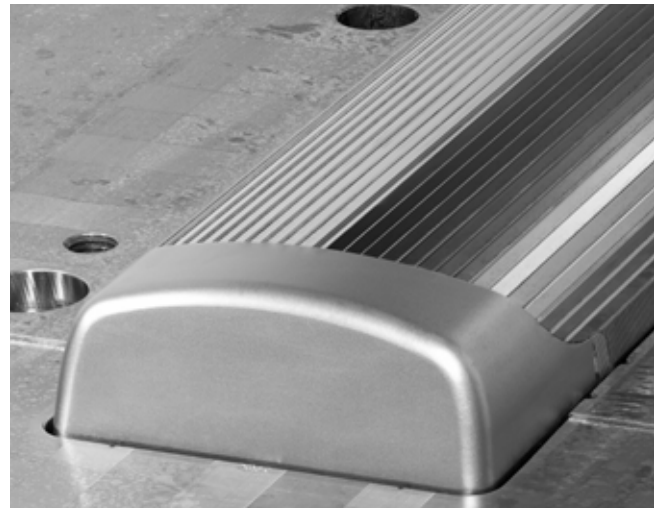

CUSTOMISED LUMINAIRES

IBV's expertise in tooling, luminaire housing manufacture, diffuser technology and electronics means we have all the skills, knowledge and capability to develop customised products for our partners.

You may have specific requirements like:

- Different lighting levels
- Alternative design life
- Various input voltages
- Built-in sensors
- Emergency lighting, or
- Options for advanced controls

IBV will be your partner in developing a specific lighting product and/or a product range with all test certificates and supporting documentation.

ADVANCED LIGHTING SOLUTIONS

The world is rapidly changing with the drive for energy efficiency and IBV is constantly innovating and adapting to meet these changes for our partners and customers.

Today, IBV offers bespoke and customised lighting solutions for both new build projects and retrofit lighting in order to:

- Adjust colour temperatures during the day
- Harvest daylight with auto dimming
- Auto test emergency lighting

IBV luminaires can be provided with control options such as:

- 0-10V dimming, DALI
- Wireless
- Networked etc.

The following table presents a summary of options available today by luminaire type.

	Product family	Motion sensor	DALI	Daylight harvest	PoE	Wireless control	Extra long lifetime	Colour temperature changing	110 Volt	Strengthened ceiling brackets	5-pole Connectors	3-pole Connectors	Available with LED tubes	Class II protection	Through wiring	Emergency kit	
Premium LED range	870-Inspire GRP	✓	✓	Q	Q	Q	Q	Q	Q	✓	✗	✓	✗	✓	✓	✓	
	870-Inspire PC	✓	✓	Q	Q	Q	Q	Q	Q	✓	✗	✓	✗	✓	✓	✓	
	870-Inspire NB	✓	✓	✗	✗	Q	Q	Q	Q	✓	✗	✓	✗	✓	✓	✓	
	870-Inspire +/-	✓	✓	Q	Q	Q	✓	Q	✗	✓	✓	✓	✗	✓	✓	✗	
	870-Inspire Air	✓	✓	Q	Q	Q	Q	Q	Q	✓	✓	✓	✗	✓	✓	✗	
	870-Farmer	✗	✗	✗	✗	✗	✗	Q	✗	✓	✗	✗	✗	Q	✓	✗	
	771-Favourite	✓	✓	Q	Q	Q	✓	Q	✓*	✓	✓	✓	✓	✓	✓	✓	✓
	771-Orient +50°C	✓	✓*	Q	Q	Q	✗	Q	Q	✓	✓	✓	✗	✓	Q	✗	
	771-Extreme -30°C	✓	✓*	Q	Q	Q	✓	Q	✗	✓	✓	✓	✗	✓	✓	✗	
	771-Ventila	✓	✓	Q	Q	Q	✗	Q	✓*	✓	✓	✓	✓*	✓	✓	✗	
	771-Farmer	✗	Q	✗	✗	✗	✗	Q	✗	✓	✗	✗	✗	Q	Q	✗	
	775-PC	✓	✓	Q	Q	Q	✓	Q	✓*	✓	✓	✓	✓	✓	✓	✓	
	793-Multiproof	✗	✓	✗	✗	Q	Q	✗	Q	✓	✓	✓	✗	Q	Q	✗	
	Standard LED range	872-Entry GRP	✓	✓	✗	✗	✗	✓	Q	Q	✓	✓	✓	✗	Q	✓	✓
872-Entry PC		✓	✓	✗	✗	✗	Q	Q	Q	✓	✗	✓	✗	Q	✓	✓	
872-Entry NB		Q	✓	Q	✗	Q	✓	Q	Q	✓	✓	✓	✗	Q	✓	✓	
792-XSlide		✗	✓	✗	✗	✗	Q	✗	Q	✓	✓	✓	✗	Q	✓	Q	

✓ Available ✗ Not available Q On request

*The luminaires can be delivered after successful tests.

The marketing materials for the above, either printed or on-line, are continuously changing. Therefore, the overview below is just to highlight some of the main versions and devices that can be combined/used with our luminaires. We would be pleased to develop your advanced lighting options upon your request.

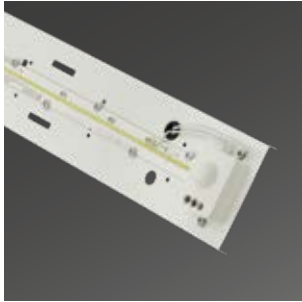

Motion sensor, corridor function



Lighting control



Daylight harvesting



Power over Ethernet (PoE) Smart Network



Wireless communication

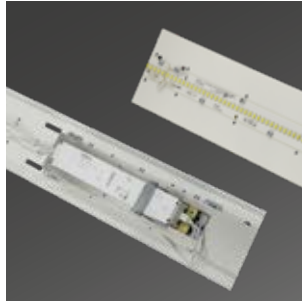

Extra long lifetime (100,000 hours)

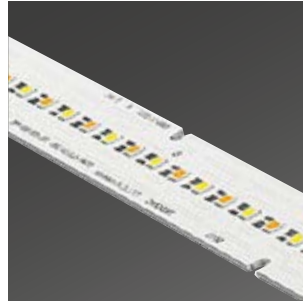

Changing of correlated colour temperature



Mains voltage 110V



Strengthened mounting brackets



Special 5-pole connectors enabling quick (in-line) installation



Special 3-pole connectors enabling quick (in-line) installation



Available with LED tubes



Quick installation

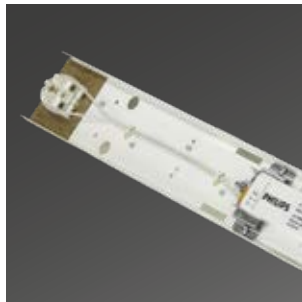

Class II protection



Through wiring







Emergency lighting

LEGEND









Symbols of concerning certification marks:

-  'CE' mark of product conformity: Conformity mark documenting conformity verification of product with all EU harmonising provisions
-  'ENEC11' marks of product quality: Licence mark indicating product conformity with European standards for electrical safety of product
-  'HACCP' mark: Hazard Analysis Critical Control Points, the declaration of conformity with legal norms for food industry
-  'DLG-approved' test mark: The light fitting complies with the relevant requirements of the German Agricultural Society (DLG) and may be installed in agricultural buildings







Symbols concerning the application:

-  Luminaires with this symbol are double insulated (Class II protection)
-  Luminaires with this mark are suitable for direct installing on normal flammable building materials, according to DIN 4102 or similar materials which have an ignition temperature of at least 200°
-  Luminaires bearing this symbol have limited surface temperature and are suitable for use in premises which are susceptible to dust and fibres.
-  Glow wire test 850°C
-  Protection level against external impact

Symbols concerning IP protection:

- 
- IP65**   Dust-tight + protected by a nozzle against enclosure from any direction shall have no harmful effects
- IP66**   Dust-tight + protected against powerful water jets
- IP67**   Dust-tight + immersed in water under defined conditions of pressure and time
- IP69**   Dust-tight + protection against high-pressure and high-temperature water directed towards the luminaire from any direction

Symbols concerning the built-in components:

-  Equipped with LED
-  Luminaires equipped with electronic control gear
-  Luminaires equipped with dimmable electronic control gear
-  Dimmable LED luminaires
- 1F**  1-Phase through wiring
- 3F**  3-Phase through wiring
-  Luminaires with emergency module

RESISTANCE TO CHEMICALS

Since the aggressive agents in liquid or gas form can destroy the plastic parts of the lighting fixtures, increased attention must be paid to the selection of the proper materials. The following table will help in this selection. It contains the most frequently used chemicals. More information can be found on our website (www.ibv.hu).

CHEMICALS	PMMA diffuser	PC diffuser housing	GRP housing
ALCOHOLS			
Alcohol up to 30%.....	+++	+++	+++
Alcohol concentrate.....	○	○	○
Methanol.....	○	○	○
Glycerine.....	+++	++	+++
Glycol.....	+++	+++	+++
AQUEOUS SOLUTIONS			
Sea water.....	+++	+++	+++
Hydrogen Peroxide up to 40%.....	○	++	○
Hydrogen Peroxide over 40%.....	○	++	○
Metal salts and their aqueous solutions.....	+++	+++	+++
Salt solutions.....	+++	+++	+++
GASES			
Carbon dioxide.....	+++	+++	+++
Carbon monoxide.....	+++	+++	+++
HYDROCARBONS			
Benzene.....	○	○	○
Diesel oil.....	+++	++	+++
Petroleum Ether.....	+++	++	+++
Aliphatic Hydrocarbons.....	++	+++	++
Aromatic Hydrocarbons.....	○	○	++
OILS			
Aniline.....	○	○	○
Machine-tool oils.....	○	○	+++
Diesel oil.....	○	○	+++
Brake oil.....	○	○	○
Flammable acid oils.....	○	++	+++
Camphor oil.....	○	○	○
Lubricating oil.....	++	+++	+++
Silicone oil.....	+++	+++	+++
Paraffin oil.....	++	+++	+++
Saturated mineral oil.....	○	○	++

	PMMA diffuser	PC diffuser housing	GRP housing
INORGANIC ACIDS			
Battery acid.....	+++	+++	+++
Bromic acid.....	○	○	○
Hydrochloric acid up to 20%.....	+++	+++	+++
Hydrochloric acid over 20%.....	+++	++	+++
Nitric acid up to 10%.....	+++	+++	+++
Nitric acid between 10% and 20%.....	++	++	++
Nitric acid over 20%.....	○	○	○
Sulphydric acid.....	+++	+++	+++
Sulphuric acid up to 50%.....	+++	+++	+++
Sulphuric acid up to 70%.....	++	++	+++
Sulphuric acid over 70%.....	○	○	○
Sulphurous acid up to 5%.....	++	○	++
ORGANIC ACIDS			
Acetic acid up to 5%.....	++	+++	+++
Acetic acid up to 30%.....	○	++	+++
Butyric acid.....	○	++	+++
Citric acid.....	++	+++	+++
Lactic acid.....	++	+++	+++
BASIC COMPOUNDS			
Ammonia 0,005% *.....	+++	○	+++
Milk of lime.....	+++	++	+++
Synthetic basic compounds.....	+++	++	+++
Sodium hydroxide up to 2%.....	+++	○	++
Sodium hydroxide up to 10%.....	+++	○	○
SOLVENTS			
Acetone.....	○	○	○
Ketone.....	○	○	○
Chlorofenol.....	○	○	○
Chloroform.....	○	○	○
Methylene Chloride.....	○	○	○
Dioxane.....	○	○	+++
Ether.....	○	○	++
Ethyl Acetate.....	○	○	○
Phenol.....	○	○	○
Methyl-ethyl ketone.....	○	○	○
Turpentine.....	++	++	+++
Pyridine.....	○	○	○
Carbon tetrachloride.....	○	○	+++
Xylene.....	○	○	○

Before selecting the product, please check the chemical environment for the lighting application. The above table refers to an ambient temperature of 25°C±10°C. The chemical resistance is only valid if there are no mechanical effects which may cause surface deformation, elongation or evolution of capillary cracks.

Legend:

+++	resistant
++	limited resistance
○	not resistant

* Occupational Exposure Limit - EC (2000)

It is recommended to consult the manufacturer before any product is selected for potentially chemically aggressive applications.

GENERAL CONDITIONS OF WARRANTY

Our products are continuously developing and hence we reserve the right to make technical modifications of the dimensions, technical data, weight and construction stated without prior written notice!

PRODUCT SEGMENTATION

LED products:

For our LED lighting products, we provide **5-3-2 years of warranty**, depending on the product as detailed below:

LED products with a 5-years warranty:

- All our products in **classic construction** with injected **silicone gasket** (except for the 870-Inspire Air and the 771-Ventila product families)
- **870-Farmer, 771-Farmer** product families - in case the customer has ordered the products with the extended 5-year warranty
- **793-Multiproof** extruded product family
- **792-XSlide** extruded product family - in case the customer has ordered the products with the extended 5-year warranty

LED products with a 3-years warranty:

- All our products in **classic construction** with non-aging **polyurethane** gasket
- **870-Farmer, 771-Farmer** product families - in case the customer has ordered the products with a 3-year warranty
- **792-XSlide** extruded product family - in case the customer has ordered the products with a 3-year warranty

Our LED products with a 2-years warranty:

- We provide a **2-year warranty** on the **870-Inspire Air** and **771-Ventila** product families.

Products designed for T5/T8 tubes:

- We provide a **2-year warranty on our luminaires for T5/T8 fluorescent tubes.**

Remarks:

Regarding any other products not stated above and/or variations on a product – such as luminaires equipped with emergency battery kit or sensor – the above extended warranty period is not applicable.

In case of versions other than the above, individual written contract with the client shall be applied.

*Date of implementation**: 01.12.2022 (Note: The warranty period must always be checked on the basis of the document in force at the time of the despatch of the product.)

The luminaires presented in this catalogue
are available **as unassembled sets**
(without electrical components) **on request.**

LED



**PREMIUM
LED RANGE**

**CLASSIC
CONSTRUCTION**

870-INSPIRE GRP

✔ TOP-PREMIUM QUALITY | **12**

870-INSPIRE PC

✔ IMPACT RESISTANT | **16**

870-INSPIRE NB

✔ NARROW BEAM FOR HIGH CEILINGS | **20**

870-INSPIRE +/-

✔ FOR EXTREME HIGH AND LOW TEMPERATURES | **24**

870-INSPIRE AIR

✔ FOR OUTDOOR APPLICATION | **28**

870-FARMER

✔ CHEMICALLY RESISTANT | **32**

771-FAVOURITE

✔ PROFESSIONAL PREMIUM | **37**

771-ORIENT +50°C

✔ FOR HIGH TEMPERATURES | **41**

771-EXTREME -30°C

✔ FOR LOW TEMPERATURES | **45**

771-VENTILA

✔ FOR OUTDOOR APPLICATION | **47**

771-FARMER

✔ CHEMICALLY RESISTANT | **51**

775-PC

✔ IMPACT RESISTANT | **54**

**EXTRUDED
PROFILE**

793-MULTIPROOF

✔ FOR FOOD INDUSTRY | **59**

**EXPLOSION-
PROOF**

SAFE-EX

✔ FOR EX ZONE 2, 22 | **62**

**CLASSIC
CONSTRUCTION**

872-ENTRY GRP

✔ PROFESSIONAL STANDARD | **66**

872-ENTRY PC

✔ IMPACT RESISTANT | **70**

872-ENTRY NB

✔ NARROW BEAM FOR HIGH CEILINGS | **74**

**EXTRUDED
PROFILE**

792-XSLIDE

✔ EXTRUDED, STANDARD QUALITY | **79**

**STANDARD
LED RANGE**

**RETROFIT
LED TUBES**

**RETROFIT LED
771-PRO LT**

✔ FOR LED TUBES | **82**

**RETROFIT LED
775-PRO LT**

✔ FOR LED TUBES | **84**

LED

870-INSPIRE GRP

High-end dust and waterproof luminaires with LED modules.

Synergy of art and technology
Inspiring design in professional quality.

YOUR MAIN BENEFITS:

Gear tray integrated into the diffuser

Cost-efficient and user-friendly **installation** even without disassembling the luminaire



870-INSPIRE GRP



IP66



Option:

IP67



1F

3F



FIELD OF APPLICATION:

Thanks to the construction principles of the gasket, the closing system and the diffuser our LED fixtures ensure a high grade of protection (IP66, on request IP67) against dust, contamination and water permeation. In accordance with their IP rating they can be widely used to illuminate spaces with dusty and humid environments.

When using outdoors, the fittings should be protected against direct sunlight and adverse weather conditions. Under 0°C the application of a venting plug or a venting cable gland is necessary, as well as the silicone gasket is recommended.

TECHNICAL DESCRIPTION AND BENEFITS:

■ **Housing:** It is made of flame retardant **GRP** - glass fibre reinforced polyester (on request suitable for 850°C glow wire test, too), in light grey (RAL7035) colour. The glass fibre reinforced polyester has a very good temperature resistance, mechanical stability. Furthermore, it is a good electrical insulator resisting the impacts of several chemicals and the impacts of weather conditions. Its stability of size and shape at changing temperatures is excellent.

■ **Diffuser: Available in PC** - injection moulded **opalised Polycarbonate** (high mechanical strength and high heat and shock resistance) **or in Acrylic** - injection moulded **opalised PMMA** (unique non-aging properties, high chemical resistance).

Further benefits:

- **Extremely high light transmissivity (up to 90%)**
- **Homogenous, well-balanced light dispersing** (no shadows)
- **Keeping the usual, well-known features of the diffuser** such as chemical and heat resistance, mechanical features, **UV stabilization** etc.
- **Universal width** (no single and twin) **simplifies the light calculation.**

■ The **gasket** between the diffuser and the housing is available in two versions:

- **Injected endless silicone foam**
- **Non-aging PU** (polyurethane) **endless foam**

■ **Fixing the diffuser to the body:** With stainless steel clips.

■ **Gear tray** (reflector): **The gear tray is integrated into the diffuser** thus enabling a **cost-efficient and user-friendly installation** even **without disassembling** the luminaire. White powder coated steel sheet, the LED modul mounting positions according to **Zhaga** standards or customized.

■ **Electrical components:** The adequate power supply is ensured with the electronic driver.

Main technical options

Our new **opalised** diffuser made of UV-stabilized material achieves an **outstanding light transmissivity up to 90%**. This great light permeability offers **high efficacy (up to 160 lm/W)** emitted from the luminaire



To protect the **LED board** the **gear tray is integrated into the diffuser** thus enabling a **cost-efficient and user-friendly quick installation** even without disassembling the luminaire.

The **stainless steel clips** stay in their position during installation and can be released by bare hands.

Compatible with all optional accessories and smart solutions

870-INSPIRE GRP

Installation friendly construction: The **strap** ensures the suspension of the gear tray and the diffuser during installation.

In order to **optimize the thermal management** of the luminaire and to **maximize the lifetime of the LED modules**, the driver is placed into the body without direct contact to the gear tray.

The **gear tray**, made of white powder coated steel sheet according to **Zhaga** standards, is **integrated into the diffuser**. With 870-Inspire GRP - depending on customer requirements - we can reach different levels of luminous flux from 2700 **up to 14000 lumen** and a maximum **efficacy of 160 lm/W**. Details see: For more details please see technical data.

The **injected silicone gasket** with enhanced resistance ensures a **maximum** chemical and weather **resistance** even under tough conditions. This endless foam sealing ensures the high IP protection up to IP67.



OPTIONS FOR CABLE ENTRY:

IP66 grommet  **LESS THAN 2 min INSTALLATION TIME**

Cable gland 

The **Rapid Connector** enables the electrical connection **without disassembling** the luminaire. 

Ways of installing (options):

With **strengthened** (0,6 mm) stainless steel mounting brackets.

1.a They are easy-to-install onto the **ceiling or the wall** (in horizontal position). 

1.b In case of vertical positioning, **special screws** keep the mounting brackets tight avoiding the luminaire from sliding. 

2 **Suspension** on chains, wire ropes etc. with stainless steel mounting brackets and **with hooks** 

Easy installation: Adjustable distance of the mounting brackets (they can be positioned laterally on the housing)

Technical data (extract)

Products with a 5-year warranty	Power (W)	Luminaire total luminous flux - emitted (lm) PC or PMMA	Lum. efficacy (lm/W) PC or PMMA	CRI	Lifetime L70B50 (Ta=35°C)	Lifetime L80B10 (Ta=35°C)	A (mm)	B (mm)	Weight (kg)	EEI
Lumnium EU with a DIP switch driver (CCT: 4000K, on request other CCTs are available)										
870 4ft (1200mm)	21/25/29/35	3100/3800/4300/5000	143	>80	> 72 000 h*	> 72 000 h*	1174	700+/- 76	2	D
870 5ft (1500mm)	24/31/37/44	3800/4700/5500/6300	143	>80	> 72 000 h*	> 72 000 h*	1454	980±76	2,2	D
870 4ft (1200mm)	21/27/32/38	3300/4100/4800/5400	143	>80	> 72 000 h*	> 72 000 h*	1174	700+/- 76	2	D
870 5ft (1500mm)	28/36/43/51	4500/5500/6300/7300	143	>80	> 72 000 h*	> 72 000 h*	1454	980±76	2,2	D
Lumnium EU PRO with a DIP switch driver (CCT: 4000K, on request other CCTs are available)										
870 4ft (1200mm)	20/25/31/36	3400/4100/5000/5700	158	>80	> 102 000 h	> 102 000 h	1174	700+/- 76	2	C
870 5ft (1500mm)	21/26/32/37	3500/4400/5200/6000	162	>80	> 102 000 h	> 102 000 h	1454	980±76	2,2	C
870 4ft (1200mm)	18/23/27/32	3100/3800/4500/5300	165	>80	> 102 000 h	> 102 000 h	1174	700+/- 76	2	C
870 5ft (1500mm)	25/30/36/43	4200/5300/6300/7300	170	>80	> 102 000 h	> 102 000 h	1454	980±76	2,2	C
Lumnium EU HF (CCT: 4000K, on request other CCTs are available)										
870 4ft (1200mm)	61	8300	135	>80	> 72 000 h	> 72 000 h	1174	700+/- 76	2	D
870 5ft (1500mm)	77	10400	135	>80	> 72 000 h	> 72 000 h	1454	980±76	2,2	D
Philips Fortimo HV6 HF 3klm/ft (CCT: 4000K, on request other CCTs are available)										
870 4ft (1200mm)	74	11300	152	>80	> 100 000 h	> 64 000 h	1174	700+/- 76	2	C
870 5ft (1500mm)	92	14000	152	>80	> 100 000 h	> 64 000 h	1454	980±76	2,2	C

* The application of through-wiring may influence the Ta. Max.



870-INSPIRE GRP

Further options:



On request:



Schematic drawing with main dimensions

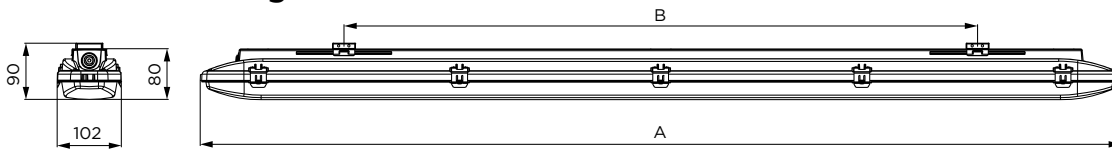

Photometric curves:

870-Inspire GRP, 4ft (1200mm),
Lumnium EU, 24W, 3500lm, PMMA

870-Inspire GRP, 5ft (1200mm),
Lumnium EU HF, 77W, 10400lm, PMMA

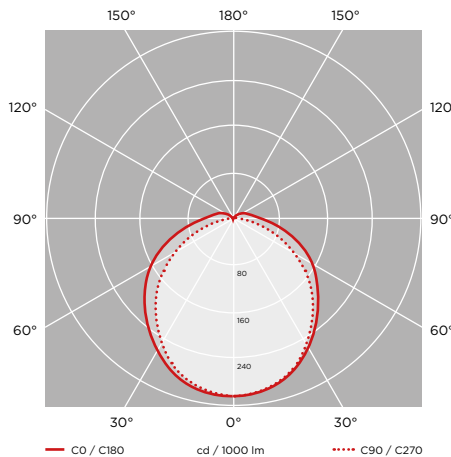
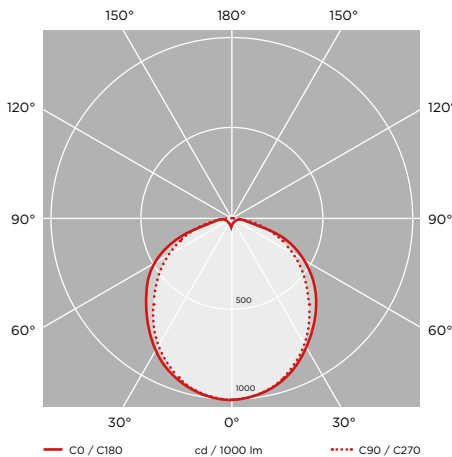

Luminaire customisation and the options of advanced controls are presented on page 5

LED

870-INSPIRE PC

High-end dust and waterproof luminaires with LED modules.

Synergy of art and technology
Inspiring design in professional quality.

YOUR MAIN BENEFITS:

Gear tray integrated into the diffuser

Cost-efficient and user-friendly installation even without disassembling the luminaire

CE



870-INSPIRE PC



IP66



Option:

IP67



FIELD OF APPLICATION:

Thanks to the construction principles of the gasket, the closing system and the diffuser our LED fixtures ensure a high grade of protection (IP66) against dust, contamination and water permeation (Optionally available in IP67). In accordance with their IP rating they can be widely used to illuminate spaces with dusty and humid environments Thanks to its **enhanced impact resistance**, 870-Inspire PC is especially suitable for applications, where a **high IK impact rating** is required. When using outdoors, the fittings should be protected against direct sunlight and adverse weather conditions. Under 0°C the application of a venting plug or a venting cable gland is necessary, as well as the silicone gasket is recommended.

TECHNICAL DESCRIPTION AND BENEFITS:

■ **Housing:** It is made of flame retardant **injection moulded Polycarbonate (PC)** in light grey (RAL7035) colour (suitable for 850°C glow wire test too). Polycarbonate has very high mechanical strength and allows us to reach an excellent shock resistance.

■ **Diffuser:** Available in **PC** - injection moulded **opalised Polycarbonate** (high mechanical strength and high heat and shock resistance - up to IK10). As an option, injection moulded acrylic (PMMA) diffuser in opal version is available.

Further benefits:

- **Extremely high light transmissivity (up to 90%)**
- **Homogenous, well-balanced light dispersing** (no shadows)
- **Keeping the usual, well known features of the diffuser** such as chemical and heat resistance, mechanical features, **UV stabilization** etc.
- **Universal width** (no single and twin) **simplifies the light calculation.**

■ The **gasket** between the diffuser and the housing is available in two versions:

- **Injected endless silicone foam**
- **Non-aging PU** (polyurethane) **endless foam**

■ **Fixing the diffuser to the body:** With stainless steel clips.

■ **Gear tray (reflector):** **The gear tray is integrated into the diffuser** thus enabling a **cost-efficient and user-friendly installation** even **without disassembling** the luminaire. White powder coated steel sheet, the LED modul mounting positions according to **Zhaga** standards or customized.

■ **Electrical components:** The adequate power supply is ensured through electronic driver.

Main technical options

Our new **opalised** diffuser made of UV-stabilized material achieves an **outstanding light transmissivity up to 90%**. This great light permeability offers **high efficacy (up to 160 lm/W)** emitted from the luminaire



To protect the **LED board**, the **gear tray is integrated into the diffuser** thus enabling a **cost-efficient and user-friendly quick installation** even without disassembling the luminaire.

The **stainless steel clips** stay in their position during installation and can be released by bare hands.

Compatible with all optional accessories and smart solutions

870-INSPIRE PC

In order to **optimize the thermal management** of the luminaire and to **maximize the lifetime of the LED modules**, the driver is placed into the body without direct contact to the gear tray.

Installation friendly construction: The **strap** ensures the suspension of the gear tray and the diffuser during installation.

The **gear tray**, made of white powder coated steel sheet according to **Zhaga** standards, is **integrated into the diffuser**. With 870-Inspire PC - depending on customer requirements - we can reach different levels of luminous flux from 3000 **up to 14000 lumen** and a maximum **efficacy of 163 lm/W**. For more details please see technical data.

The injected **silicone gasket** with enhanced resistance ensures **maximum** chemical and weather **resistance** even under tough conditions. This endless foam sealing ensures the high IP protection up to IP67.

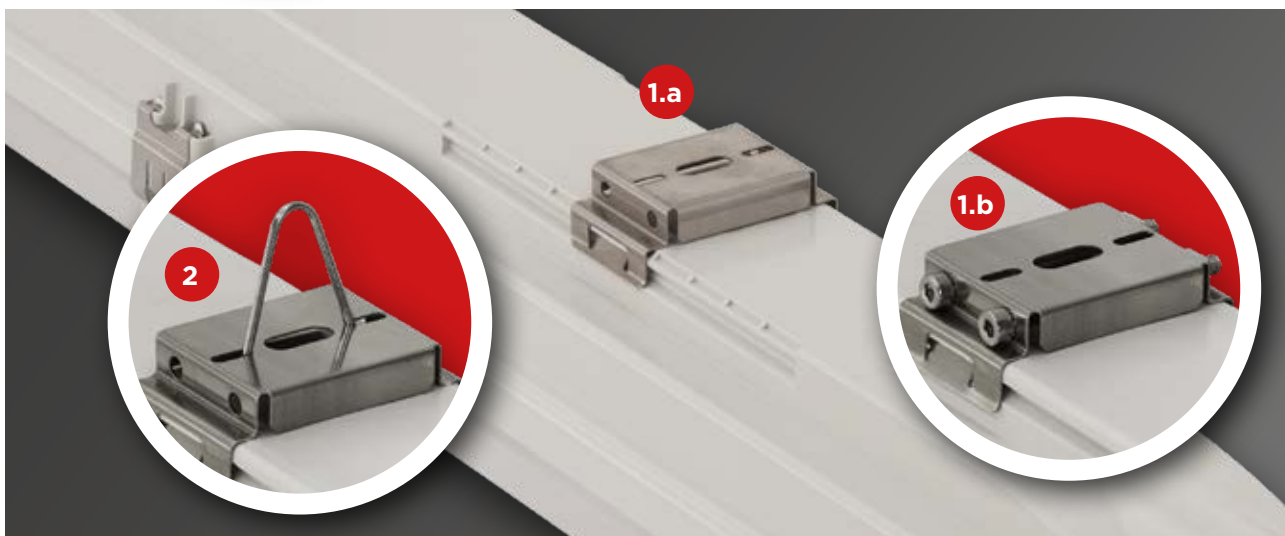
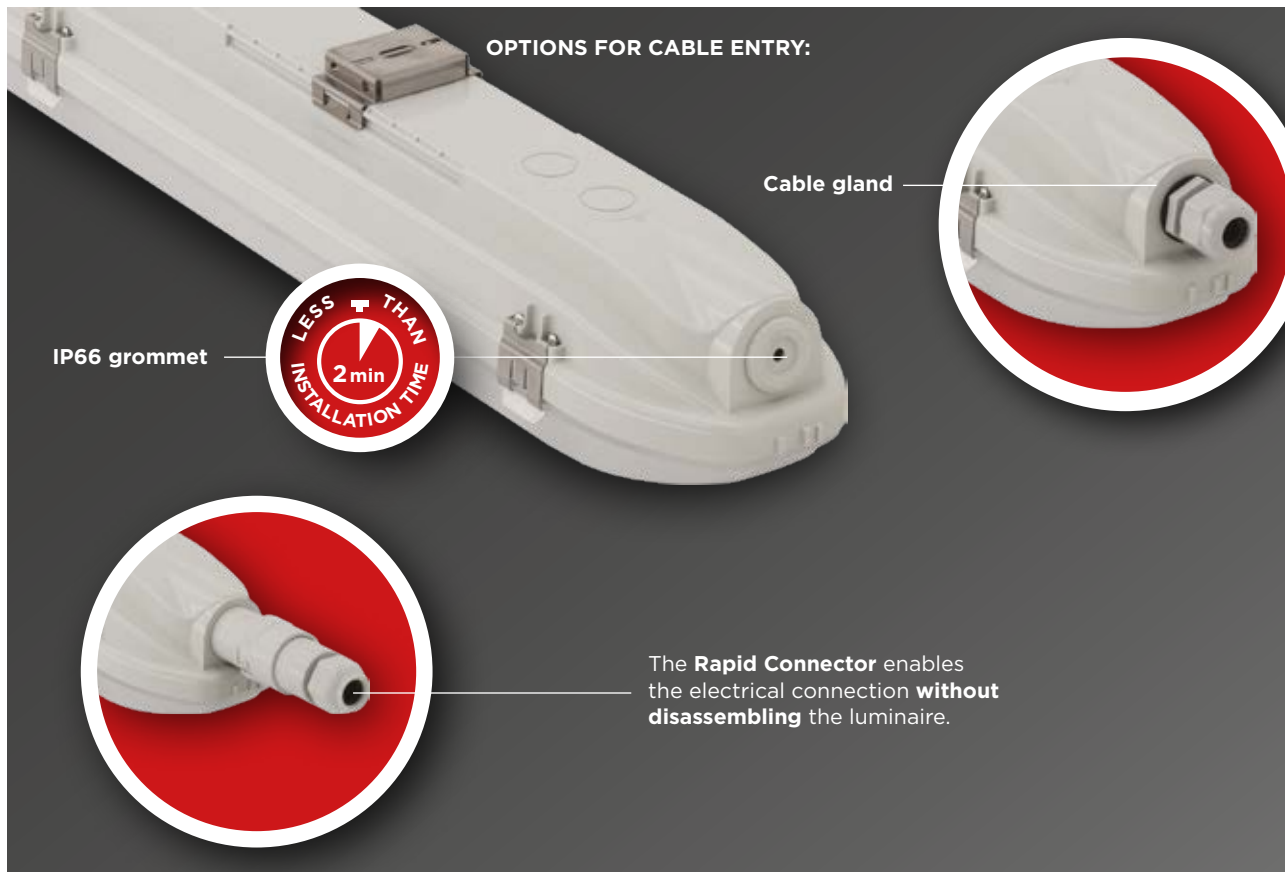

Ways of installing (options):

With **strengthened** (0,6 mm) stainless steel mounting brackets.

1.a They are easy-to-install onto the **ceiling or the wall** (in horizontal position).

1.b In case of vertical positioning, **special screws** keep the mounting brackets tight avoiding the luminaire from sliding.

2 **Suspension** on chains, wire ropes etc. with stainless steel mounting brackets and **with hooks**.
Easy installation: Adjustable distance of the mounting brackets (they can be positioned laterally on the housing)

Technical data (extract)

Products with a 5-year warranty	Power (W)	Luminaire total luminous flux - emitted (lm) PC or PMMA	Lum. efficacy (lm/W) PC or PMMA	CRI	Lifetime L70B50 (Ta=35°C)	Lifetime L80B10 (Ta=35°C)	A (mm)	B (mm)	Weight (kg)	EEL
Lumnium EU with a DIP switch driver (CCT: 4000K, on request other CCTs are available)										
870 2ft (600mm)	19/24	2700/3300	142	>80	> 72 000 h*	> 72 000 h*	615	300±25	0,9	D
870 4ft (1200mm)	21/25/29/35	3100/3800/4300/5000	143	>80	> 72 000 h*	> 72 000 h*	1174	700+/- 76	2	D
870 5ft (1500mm)	24/31/37/44	3800/4700/5500/6300	143	>80	> 72 000 h*	> 72 000 h*	1454	980+/- 76	2,2	D
870 4ft (1200mm)	21/27/32/38	3300/4100/4800/5400	143	>80	> 72 000 h*	> 72 000 h*	1174	700+/- 76	2	D
870 5ft (1500mm)	28/36/43/51	4500/5500/6300/7300	143	>80	> 72 000 h*	> 72 000 h*	1454	980+/- 76	2,2	D
Lumnium EU PRO with a DIP switch driver (CCT: 4000K, on request other CCTs are available)										
870 4ft (1200mm)	20/25/31/36	3400/4100/5000/5700	158	>80	> 102 000 h	> 102 000 h	1174	700+/- 76	2	C
870 5ft (1500mm)	21/26/32/37	3500/4400/5200/6000	162	>80	> 102 000 h	> 102 000 h	1454	980+/- 76	2,2	C
870 4ft (1200mm)	18/23/27/32	3100/3800/4500/5300	165	>80	> 102 000 h	> 102 000 h	1174	700+/- 76	2	C
870 5ft (1500mm)	25/30/36/43	4200/5300/6300/7300	170	>80	> 102 000 h	> 102 000 h	1454	980+/- 76	2,2	C
Lumnium EU HF (CCT: 4000K, on request other CCTs are available)										
870 4ft (1200mm)	61	8300	136	>80	> 72 000 h	> 72 000 h	1174	700+/- 76	2	D
870 5ft (1500mm)	77	10400	135	>80	> 72 000 h	> 72 000 h	1454	980+/- 76	2,2	D
Philips Fortimo HV6 HF 3klm/ft (CCT: 4000K, on request other CCTs are available)										
870 4ft (1200mm)	74	11300	152	>80	> 100 000 h	> 64 000 h	1174	700+/- 76	2	C
870 5ft (1500mm)	92	14000	152	>80	> 100 000 h	> 64 000 h	1454	980+/- 76	2,2	C

* The application of through-wiring may influence the Ta. Max.



Further options:



On request:



Schematic drawing with main dimensions

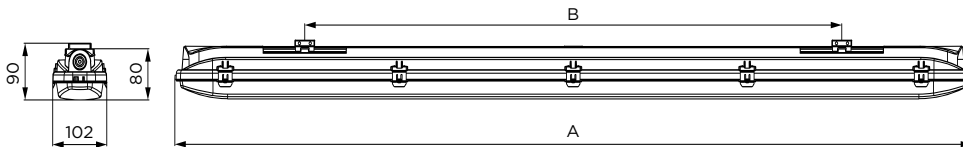

Photometric curves:

870-Inspire PC, 4ft (1200mm),
Lumnium EU, 24W, 3500lm, PC

870-Inspire PC, 5ft (1500mm),
Lumnium EU HF, 77W, 10400lm, PC

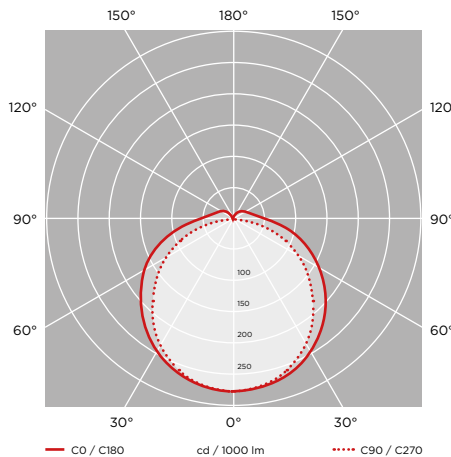
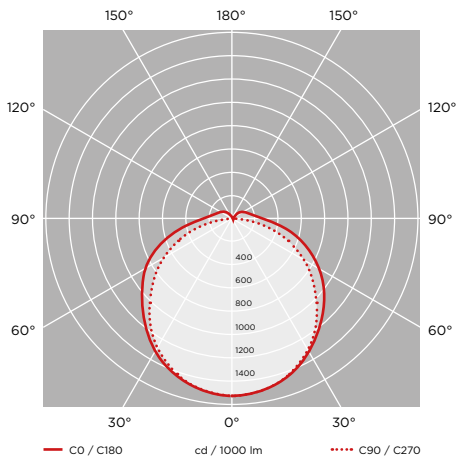

Luminaire customisation and the options of advanced controls are presented on page 5

LED

870-INSPIRE NB

High-end dust and waterproof luminaires with LED modules and with narrow beam optics.

Synergy of art and technology. Perfect choice for high ceilings!

YOUR MAIN BENEFITS:

Narrow beam luminaire, suitable for high ceilings, with a transparent diffuser and narrow beam optics
Ideal alternative to high bay fixtures, in a more cost-effective performance

CE

870-INSPIRE NB



IP66



Option:

IP67



1F

3F



FIELD OF APPLICATION:

Thanks to the construction principles of the gasket, the closing system and the diffuser our LED fixtures ensure a high grade of protection (IP66) against dust, contamination and water permeation. In accordance with their IP rating they can be widely used to illuminate spaces with dusty and humid environments.

When using outdoors, the fittings should be protected against direct sunlight and adverse weather conditions. Under 0°C the application of a venting plug or a venting cable gland is necessary, as well as the silicone gasket is recommended.

TECHNICAL DESCRIPTION AND BENEFITS:

■ **Housing: Available in** flame retardant **GRP** - glass fibre reinforced polyester (on request suitable for 850°C glow wire test too), in light grey (RAL7035) colour. The glass fibre reinforced polyester has a very good temperature resistance and mechanical stability. Furthermore, it is a good electrical insulator resisting the impacts of several chemicals and weather conditions. Its stability of size and shape at changing temperatures is excellent.

Or also available in flame retardant **injection moulded polycarbonate (PC)** (suitable for 850°C glow wire test), in light grey (RAL7035) colour. This material has very high mechanical strength and allows us to reach an excellent shock resistance.

■ **Diffuser: Available in PC** - injection moulded **transparent Polycarbonate** (high mechanical strength and high heat and shock resistance) **or in Acrylic** - injection moulded **transparent PMMA** (unique non-aging properties, high chemical resistance). With a transparent diffuser a 40° narrow beam radiation angle is achievable for high bay applications.

Further benefits:

- **Extremely high light transmissivity (up to 93%)**
- **Homogenous, well-balanced light dispersing** (no shadows)
- **Keeping the usual, well known features of the diffuser** such as chemical and heat resistance, mechanical features, **UV stabilization** etc.
- **Universal width** (no single and twin) **simplifies the light calculation.**

■ The **gasket** between the diffuser and the housing is available in two versions:

- **Injected endless silicone foam**
- **Non-aging PU** (polyurethane) **endless foam**

■ **Fixing the diffuser to the body:** With stainless steel clips.

■ **Gear tray (reflector): The gear tray is integrated into the diffuser** thus enabling a **cost-efficient and user-friendly installation** even **without disassembling** the luminaire. White powder coated steel sheet, the LED modul mounting positions according to **Zhaga** standards or customized.

■ **Electrical components:** The adequate power supply is ensured through electronic driver.

20

Main technical options

Our **transparent** diffuser made of UV-stabilized material achieves an **outstanding light transmissivity up to 93%**. This great light permeability offers **high efficacy (up to 157 lm/W)** emitted from the luminaire.



Narrow beam optics



To protect the **LED board**, the **gear tray is integrated into the diffuser** thus enabling a **cost-efficient and user-friendly quick installation** even without disassembling the luminaire.

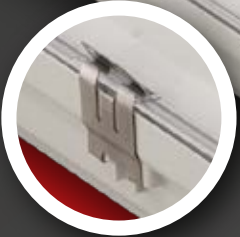

The **stainless steel clips** stay in their position during installation and can be released by bare hands.



Compatible with all optional accessories and smart solutions



870-INSPIRE NB

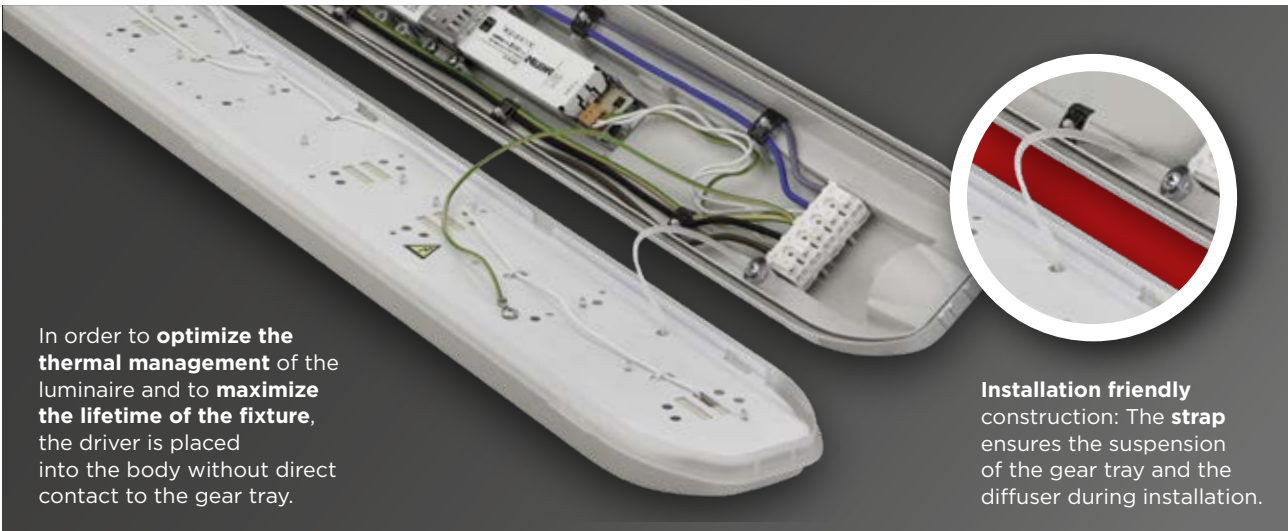

In order to **optimize the thermal management** of the luminaire and to **maximize the lifetime of the fixture**, the driver is placed into the body without direct contact to the gear tray.



Installation friendly construction: The **strap** ensures the suspension of the gear tray and the diffuser during installation.

The **gear tray**, made of white powder coated steel sheet according to **Zhaga** standards, is **integrated into the diffuser**. With 870-Inspire NB - depending on customer requirements - we can reach different levels of luminous flux **up to 10400 lumen** and a maximum **efficacy of 165 lm/W**. For more details please see technical data.

The injected **silicone gasket** with enhanced resistance ensures **maximum** chemical and weather **resistance** even under tough conditions. This endless foam sealing ensures the high IP protection up to IP67.



OPTIONS FOR CABLE ENTRY:

IP66 grommet

LESS THAN 2 min INSTALLATION TIME

Cable gland

The **Rapid Connector** enables the electrical connection **without disassembling** the luminaire.

Ways of installing (options):

1.a

2

1.b

With **strengthened** (0,6 mm) stainless steel mounting brackets.

1.a They are easy-to-install onto the **ceiling or the wall** (in horizontal position).

1.b In case of vertical positioning, position **fixing screws** keep the mounting brackets tight avoiding the luminaire from sliding.

2. **Suspension** on chains, wire ropes etc. with stainless steel mounting brackets and **with hooks**.

Easy installation: Adjustable distance of the mounting brackets (they can be positioned laterally on the housing)

Technical data (extract)

Products with a 5-year warranty	Power (W)	Luminaire total luminous flux - emitted (lm) PC or PMMA	Lum. efficacy (lm/W) PC or PMMA	CRI	Lifetime L70B50 (Ta=35°C)	Lifetime L80B10 (Ta=35°C)	A (mm)	B (mm)	Weight (kg)	EEL
Lumnium EU with a DIP switch driver (CCT: 4000K, on request other CCTs are available)										
870 4ft (1200mm)	21/27/32/38	3300/4100/4800/5400	143	>80	> 72 000 h*	> 72 000 h*	1174	700 +/- 76	2	D
870 5ft (1500mm)	28/36/43/51	4500/5500/6300/7300	143	>80	> 72 000 h*	> 72 000 h*	1454	980 +/- 76	2,2	C
Lumnium EU PRO with a DIP switch driver (CCT: 4000K, on request other CCTs are available)										
870 4ft (1200mm)	18/23/27/32	3100/3800/4500/5300	165	>80	> 102 000 h	> 102 000 h	1174	700 +/- 76	2	D
870 5ft (1500mm)	25/30/36/43	4200/5300/6300/7300	170	>80	> 102 000 h	> 102 000 h	1454	980 +/- 76	2,2	C
Lumnium EU HF (CCT: 4000K, on request other CCTs are available)										
870 4ft (1200mm)	61	8600	165	>80	> 72 000 h	> 72 000 h	1174	700 +/- 76	2	D
870 5ft (1500mm)	77	10800	170	>80	> 72 000 h	> 72 000 h	1454	980 +/- 76	2,2	C
Philips Fortimo HV6 HF 3klm/ft (CCT: 4000K, on request other CCTs are available)										
870 4ft (1200mm)	74	11600	157	>80	> 100 000 h	> 64 000 h	1174	700 +/- 76	2	D
870 5ft (1500mm)	92	14500	157	>80	> 100 000 h	> 64 000 h	1454	980 +/- 76	2,2	C

* The application of through-wiring may influence the Ta. Max.



870-INSPIRE NB

Further options:



On request:



Schematic drawing with main dimensions

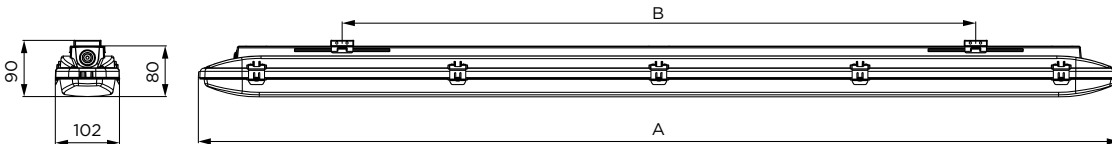

Photometric curves:

870-Inspire NB, 5ft (1500mm),
Philips Fortimo HV6 HF, 92W, 14500lm,
PMMA

With the use of a transparent diffuser
a 40° narrow beam radiation angle is
can be achieved in case of high bay applications.

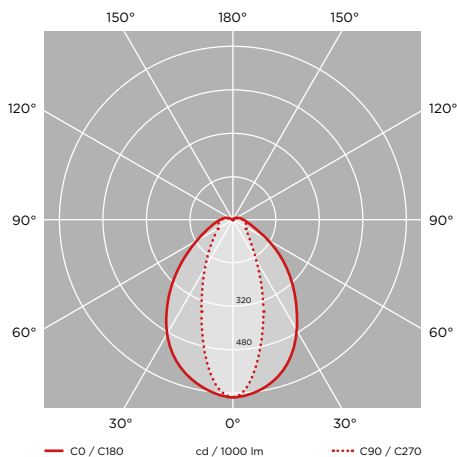

Luminaire customisation and the options of advanced controls are presented on page 5

LED

870-INSPIRE +/-

High-end dust and waterproof luminaires with LED modules.

Professional quality suitable for wide application

2-in-1: Error-free functioning at extreme ambient temperature

YOUR MAIN BENEFITS:

A professional luminaire adapted for **extremely high and extremely low** ambient temperatures. (Ta: -30 to +60 °C) for wide usage, that fulfils the strongest quality requirements.

CE**870-INSPIRE +/-****IP66**

Option:



FIELD OF APPLICATION:

Thanks to the construction principles of the gasket, the closing system and the diffuser our LED fixtures ensure a high grade of protection (IP66) against dust, contamination and water permeation. In accordance with their IP rating they can be widely used to illuminate spaces with dusty and humid environments. Thanks to its **enhanced temperature resistance**, 870-Inspire +/- is especially suitable for applications, where **error-free functioning at high and low ambient temperature** is desired (industrial plants, cold stores, in countries with subtropic climate...etc.) When using outdoors, the fittings should be protected against direct sunlight and adverse weather conditions. Under 0°C the application of a venting plug or a venting cable gland is necessary.

TECHNICAL DESCRIPTION AND BENEFITS:

- **Housing: Available with PC or GRP body**, in light grey (RAL7035) colour.
In case of PC: It is made of flame retardant **injection moulded polycarbonate (PC)** - suitable for 850°C glow wire test too-, the Polycarbonate has very high mechanical strength and allows us to reach an excellent shock resistance. In case of GRP: It is made of flame retardant **GRP - glass fibre reinforced polyester** - on request suitable for 850°C glow wire test, too. The glass fibre reinforced polyester has a very good temperature resistance and mechanical stability. Furthermore, it is a good electrical insulator resisting the impacts of several chemicals and weather conditions. Its stability of size and shape at changing temperatures is excellent.
 - **Diffuser: Available in PC** - injection moulded **opalised polycarbonate** (high mechanical strength and high heat and shock resistance). Thanks to its **enhanced impact resistance**, 870-Inspire +/- is especially suitable for applications, where **a high IK impact rating** at extreme ambient temperature is required.
- Further benefits:**
- **Extremely high light transmissivity (up to 90%)**
 - **Homogenous, well-balanced light dispersing** (no shadows)
 - **Keeping the usual, well known features of the diffuser** such as chemical and heat resistance, mechanical features, **UV stabilization** etc.
 - **Universal width** (no single and twin) **simplifies the light calculation.**
- The **gasket** between the diffuser and housing is **Injected endless silicone foam.**
 - **Fixing the diffuser to the body:** With **stainless steel** clips.
 - **Gear tray (reflector): The gear tray is integrated into the diffuser** thus enabling a **cost-efficient and user-friendly installation** even **without disassembling** the luminaire. White powder coated steel sheet, the LED modul mounting positions according to **Zhaga** standards or customized.
 - **Electrical components:** The adequate power supply is ensured through electronic driver.

LED SOLUTIONS

Main technical options

Our new **opalised** diffuser made of UV-stabilized material achieves an **outstanding light transmissivity up to 90%**. This great light permeability offers **high efficacy (up to 141 lm/W)** emitted from the luminaire.



To protect the **LED board**, the **gear tray is integrated into the diffuser** thus enabling a **cost-efficient and user-friendly quick installation** even without disassembling the luminaire.



The **stainless steel clips** stay in their position during installation and can be released by bare hands.



Compatible with all optional accessories and smart solutions



Installation friendly construction: The **strap** ensures the suspension of the gear tray and the diffuser during installation.

In order to optimise the thermal management of the luminaire at high ambient temperatures, the driver is fixed to the gear tray with a **heat sink plate**. Thus heat sensitive LED components function properly **up to Ta +60 °C**.

Extra-long (double) lifetime of the driver and high luminous flux even at extreme ambient temperatures are your benefits.

The **gear tray**, made of white powder coated steel sheet according to **Zhaga** standards, is **integrated into the diffuser**. With 870-Inspire +/- - depending on customer requirements - we can reach different levels of luminous flux **up to 10400 lm** and a maximum **efficiency of 153 lm/W**. For more details please see technical data.

870-INSPIRE +/-

The injected **silicone gasket** with enhanced resistance ensures **maximum** chemical and weather **resistance** even under tough conditions. This endless foam sealing ensures the high IP protection up to IP67.



OPTIONS FOR CABLE ENTRY:

In case of **standard version** a **venting cable gland** is applied



The **Rapid Connector** enables the electrical connection **without disassembling** the luminaire.

In case of a throughgoing wiring with **rapid connectors on both ends**, a **venting plug** is applied.

Thanks to the **venting cable gland** or the **venting plug** the **condensation of the humidity** inside the luminaire can be **avoided**.

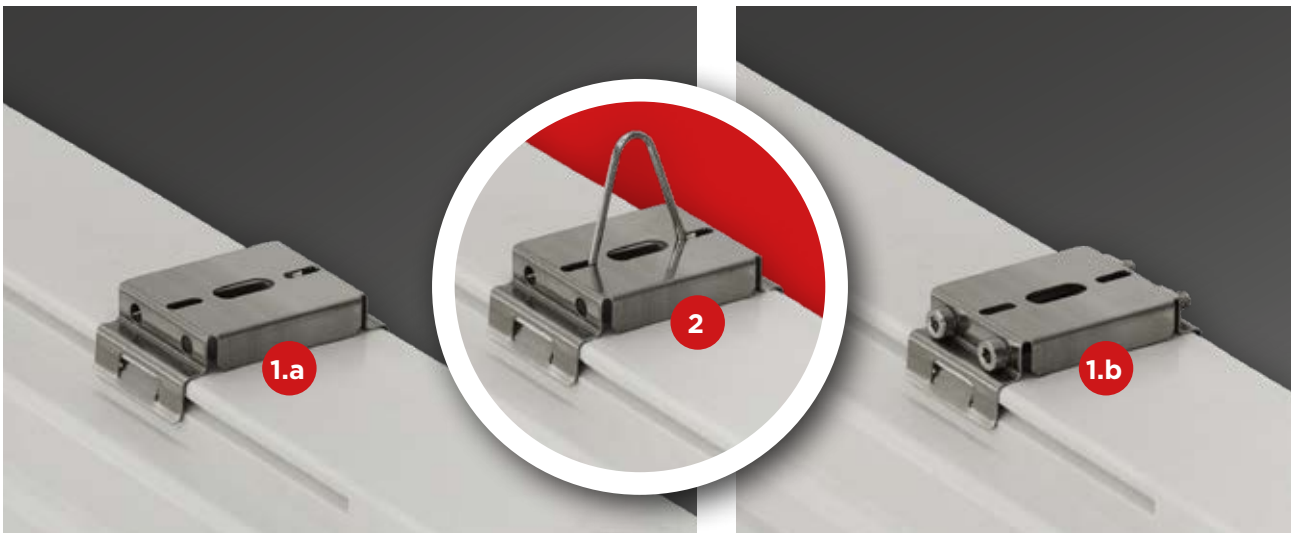

Ways of installing (options):

With **strengthened** (0,6 mm) stainless steel mounting brackets.
 1.a They are easy-to-install onto the **ceiling or the wall** (in horizontal position).
 1.b In case of vertical positioning, **position fixing screws** keep the mounting brackets tight avoiding the luminaire from sliding.

2. **Suspension** on chains, wire ropes etc. with stainless steel mounting brackets and **with hooks**.
Easy installation: Adjustable distance of the mounting brackets (they can be positioned laterally on the housing)

Technical data (extract)



Products with a 5-year warranty	Power (W)	Luminaire total luminous flux emitted (lm) PC	Lum. efficacy (lm/W) PC	CRI	Lifetime L80B10 (Ta=50°C)	Lifetime L90B10 (Ta=50°C)	A (mm)	B (mm)	Weight (kg)	EEL
---------------------------------	-----------	---	-------------------------	-----	---------------------------	---------------------------	--------	--------	-------------	-----

870 Philips Fortimo HV6 with Philips driver

870 4ft (1200mm)	59	8700	147	>80	>64.000 h	>50.000 h	1174	700+/-76	2	C
870 5ft (1500mm)	70	10400	148	>80	>64.000 h	>50.000 h	1454	1000+/-76	2,2	C

Products with a 5-year warranty	Power (W)	Luminaire total luminous flux emitted (lm) PC	Lum. efficacy (lm/W) PC	CRI	Lifetime L80B10 (Ta=60°C)	Lifetime L90B10 (Ta=60°C)	A (mm)	B (mm)	Weight (kg)	EEL
---------------------------------	-----------	---	-------------------------	-----	---------------------------	---------------------------	--------	--------	-------------	-----

870 Philips Fortimo HV6 with Philips driver

870 4ft (1200mm)	51	7400	145	>80	>64.000 h	>50.000 h	1174	700+/-76	2	C
870 5ft (1500mm)	56	9500	153	>80	>64.000 h	>50.000 h	1454	980+/-76	2,2	C

870-INSPIRE +/-

Further options:



On request:



Schematic drawing with main dimensions

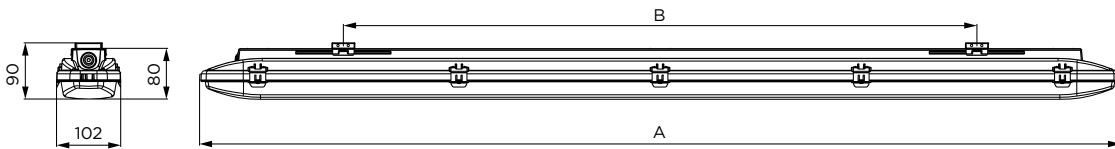

Photometric curves:

870-Inspire +/-, 4ft (1200mm), Philips Fortimo HV6 HF, 59W, 8700lm, PC

870-Inspire +/-, 5ft (1500mm), Philips Fortimo HV6 HF, 56W, 9500lm, PC

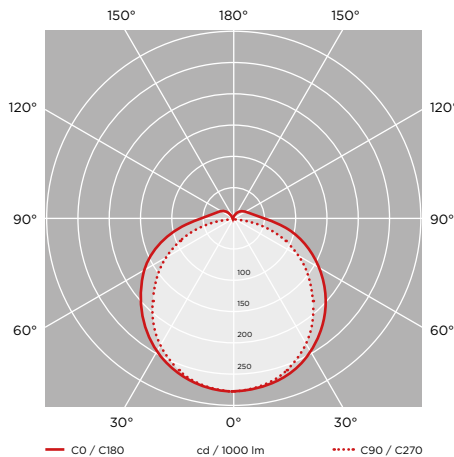
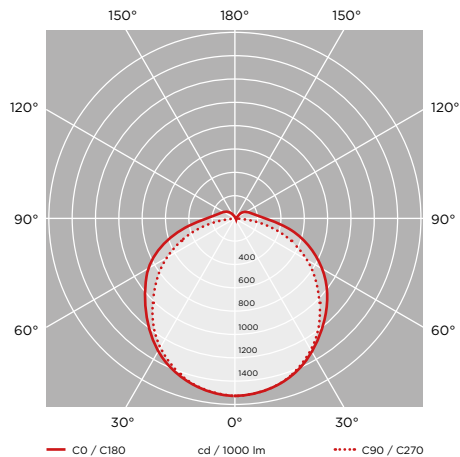

Luminaire customisation and the options of advanced controls are presented on page 5

LED

870-INSPIRE AIR

High-end dust and waterproof luminaires for outdoor with LED modules.

A professional solution especially for outdoor applications. 870-Inspire Air withstands the impact of adverse weather conditions.

YOUR MAIN BENEFITS:

Enhanced weather resistance (sunlight, rain, wind). Suitable for outdoor applications with errorfree functioning. Gear tray integrated into the diffuser. Quick installation even without disassembling the luminaire.



870-INSPIRE AIR

IP66

FIELD OF APPLICATION:

Thanks to the construction principles of the gasket, the closing system and the diffuser our fixtures ensure a high grade of protection (IP66) against dust, contamination and water permeation. In accordance with their IP grade they can be used widely to illuminate areas with dusty and humid environment.

Thanks to its enhanced weather resistance, **870-Inspire Air** is especially suitable for applications, where **errorfree functioning in outdoor conditions** is desired.

TECHNICAL DESCRIPTION AND BENEFITS:

■ **Housing:** Available flame retardant **GRP** - glass fibre reinforced polyester in light grey (RAL7035) colour. The glass fibre reinforced polyester has a very good temperature resistance and mechanical stability. Furthermore, it is a good electrical insulator resisting the impacts of several chemicals and weather conditions. Its stability of size and shape at changing temperatures is excellent.

■ **Diffuser:** is available in injection moulded **opalised Acrylic PMMA** with unique non-aging properties, extremely high light permeability and well-balanced light dispersing. The diffusers are designed with respect to their optical characteristics and are UV resistant. Main advantages: **weather resistance** and extremely high light efficiency.

Further benefits:

- **Extremely high light transmissivity (up to 90%)**
- **Homogenous, well-balanced light dispersing** (no shadows)
- Keeping the usual, well known features of the diffuser such as **chemical and heat resistance, mechanical features, UV stabilization** etc.
- **Universal width** (no single and twin) simplifies the light calculation

■ The **gasket** between the diffuser and housing is **Injected endless silicone** foam.

■ **Fixing the diffuser to the body:** With **stainless steel** clips.

■ **Gear tray (reflector):** The **gear tray is integrated into the diffuser** thus enabling a **cost-efficient and user-friendly installation** even **without disassembling** the luminaire. White powder coated steel sheet according to **Zhaga** standards or customized.

■ **Electrical components:** The adequate power supply is ensured through electronic driver.

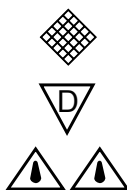

Option:



Main technical options

Our new **opalised** diffuser made of UV-stabilized material achieves an **outstanding light transmissivity up to 90%**. This great light permeability offers **high efficacy (up to 160 lm/W)** emitted from the luminaire.



LED

870-INSPIRE AIR



The **stainless steel clips** stay in their position during installation and can be released by bare hands.

Compatible with all optional accessories and smart solutions!



To protect the **LED board**, the **gear tray** is integrated into the diffuser thus enabling a **cost-efficient and user-friendly quick installation** even without disassembling the luminaire.

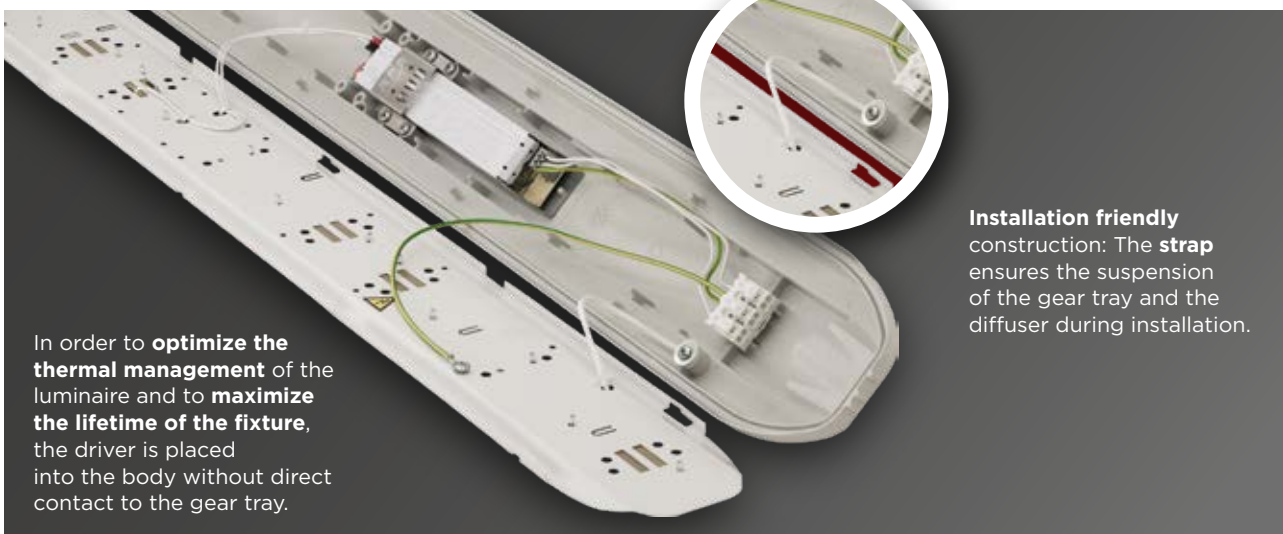

In order to **optimize the thermal management** of the luminaire and to **maximize the lifetime of the fixture**, the driver is placed into the body without direct contact to the gear tray.

Installation friendly construction: The **strap** ensures the suspension of the gear tray and the diffuser during installation.

The **gear tray**, made of white powder coated steel sheet according to **Zhaga** standards, **is integrated into the diffuser**. With **870-Inspire Air** - depending on customer requirements - we can reach different levels of luminous flux from 2700 **up to 14000 lumen** with maximum of **efficacy 163 lm/W**. For more details please see technical data.

The injected **silicone gasket** with enhanced resistance ensures **maximum** chemical and weather **resistance** even under tough conditions. This endless foam sealing ensures the high IP protection up to IP67.



OPTIONS FOR CABLE ENTRY:

LESS THAN 2 min INSTALLATION TIME

Venting cable gland

Comes with **venting cable gland** in order to prevent the build-up of moisture inside the luminaire thus avoiding its damage.

The **Rapid Connector** enables the electrical connection **without disassembling** the luminaire.

The **venting plug** is a pressure equalizer instead of the venting cable gland in case of the application of a rapid connector



Ways of installing (options):

With **strengthened** (0,6 mm) stainless steel mounting brackets.

1.a They are easy-to-install onto the **ceiling or the wall** (in horizontal position).

1.b In case of vertical positioning, **special screws** keep the mounting brackets tight avoiding the luminaire from sliding.

Easy installation: Adjustable distance of the mounting brackets (they can be positioned laterally on the housing)

Technical data (extract)

Products with a 2-year warranty	Power (W)	Luminare total luminous flux - emitted (lm) PMMA	Lum. efficacy (lm/W) PMMA	CRI	Lifetime L70B50 (Ta=35°C)	Lifetime L80B10 (Ta=35°C)	A (mm)	B (mm)	Weight (kg)	EEL
Lumnium EU with a DIP switch driver (CCT: 4000K, on request other CCTs are available)										
870 4ft (1200mm)	21/25/29/35	3100/3800/4300/5000	143	>80	> 72 000 h*	> 72 000 h*	1174	700 +/- 76	2	D
870 5ft (1500mm)	24/31/37/44	3800/4700/5500/6300	143	>80	> 72 000 h*	> 72 000 h*	1454	980 +/- 76	2,2	D
870 4ft (1200mm)	21/27/32/38	3300/4100/4800/5400	143	>80	> 72 000 h*	> 72 000 h*	1174	700 +/- 76	2	D
870 5ft (1500mm)	28/36/43/51	4500/5500/6300/7300	143	>80	> 72 000 h*	> 72 000 h*	1454	980 +/- 76	2,2	D
Lumnium EU PRO with a DIP switch driver (CCT: 4000K, on request other CCTs are available)										
870 4ft (1200mm)	20/25/31/36	3400/4100/5000/5700	158	>80	> 102 000 h	> 102 000 h	1174	700 +/- 76	2	C
870 5ft (1500mm)	21/26/32/37	3500/4400/5200/6000	162	>80	> 102 000 h	> 102 000 h	1454	980 +/- 76	2,2	C
870 4ft (1200mm)	18/23/27/32	3100/3800/4500/5300	165	>80	> 102 000 h	> 102 000 h	1174	700 +/- 76	2	C
870 5ft (1500mm)	25/30/36/43	4200/5300/6300/7300	170	>80	> 102 000 h	> 102 000 h	1454	980 +/- 76	2,2	C
Lumnium EU HF (CCT: 4000K, on request other CCTs are available)										
870 4ft (1200mm)	61	8300	136	>80	> 72 000 h	> 72 000 h	1174	700 +/- 76	2	D
870 5ft (1500mm)	77	10400	136	>80	> 72 000 h	> 72 000 h	1454	980 +/- 76	2,2	D
Philips Fortimo HV6 HF 3klm/ft (CCT: 4000K, on request other CCTs are available)										
870 4ft (1200mm)	74	11300	152	>80	> 100 000 h	> 64 000 h	1174	700 +/- 76	2	C
870 5ft (1500mm)	92	14000	152	>80	> 100 000 h	> 64 000 h	1454	980 +/- 76	2,2	C

* The application of through-wiring may influence the Ta. Max.



Further options:



On request:



Schematic drawing with main dimensions

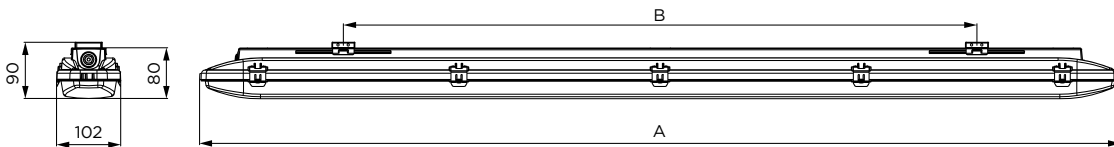

Photometric curves:

870-Inspire Air, 4ft (1200mm),
Lumnium EU, 24W, 3500lm, PMMA

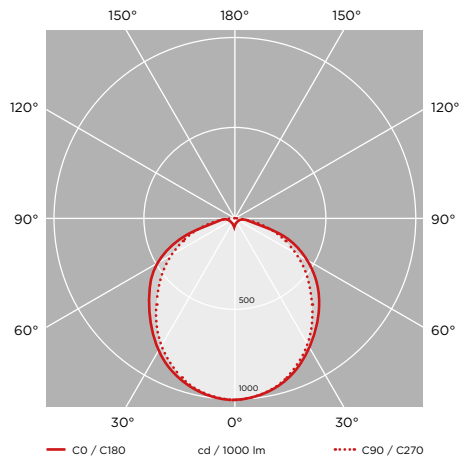

870-Inspire Air, 5ft (1500mm),
Lumnium EU HF 77W, 10400lm, PMMA

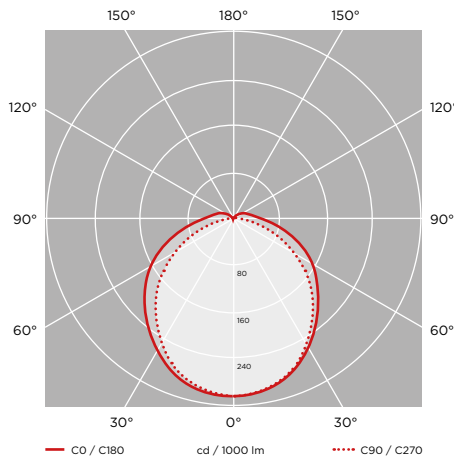

Luminaire customisation and the options of advanced controls are presented on page 5

LED

870-FARMER

High-end dust and waterproof luminaires with LED modules.

Perfect choice for farming industry and chemically aggressive environments!

YOUR MAIN BENEFITS:

Corrosion resistant luminaire, designed for **long-term resistance** against chemicals, **especially ammonia**. Gear tray integrated into the diffuser, **user-friendly installation**.

CE

870-FARMER



IP66



Option:



1F

3F



FIELD OF APPLICATION:

Thanks to the construction principles of the gasket, the closing system and the diffuser our LED fixtures ensure a high grade of protection (IP66) against dust, contamination and water permeation. In accordance with their IP rating they can be widely used to illuminate spaces with dusty and humid environments.

When using outdoors, the fittings should be protected against direct sunlight and adverse weather conditions. Under 0°C the application of a venting plug or a venting cable gland is necessary.

TECHNICAL DESCRIPTION AND BENEFITS:

- **Housing:** It is made of flame retardant **GRP** - glass fibre reinforced polyester (on request suitable for 850°C glow wire test, too), in light grey (RAL7035) colour. The glass fibre reinforced polyester has a very good temperature resistance and mechanical stability. Furthermore, it is a good electrical insulator resisting the impacts of several chemicals and weather conditions. Its stability of size and shape at changing temperatures is excellent.
- **Diffuser: Available in Acrylic** - injection moulded **opalised PMMA** (unique non-aging properties, high chemical resistance).
 - **Further benefits:**
 - **Extremely high light transmissivity (up to 93%)**
 - **Homogenous, well-balanced light dispersing** (no shadows)
 - **Keeping the usual, well known features of the diffuser** such as chemical and heat resistance, mechanical features, **UV stabilization** etc.
 - **Universal width** (no single and twin) **simplifies the light calculation.**
- **Gasket: Injected endless silicone foam** with enhanced resistance.
- **Fixing the diffuser to the body:** with **stainless steel clips**.
- **Gear tray (reflector):** The gear tray is integrated into the diffuser thus enabling a **cost-efficient and user-friendly installation** even without disassembling the luminaire. White powder coated steel sheet, the LED module mounting positions according to **Zhaga** standards or customized.
- **Electrical components:** The adequate power supply is ensured through a special **hermetically sealed electronic driver - LUMNIUM Farmer HV.**

Main technical options

Our new **opalised** diffuser made of UV-stabilized material achieves an **outstanding light transmissivity up to 93%**. This great light permeability offers **high efficacy (up to 164 lm/W)** emitted from the luminaire.



The **maximum of chemical resistance** achieved by using **special components**:

Tinned wires

Hermetically sealed driver

Corrosion resistant LED system, LUMNIUM Farmer HV, designed for long-term resistance against chemicals, especially ammonia.

870-FARMER

Installation friendly construction: The **strap** ensures the suspension of the gear tray and the diffuser during installation.

In order to **optimize the thermal management** of the luminaire and to **maximize the lifetime of the fixture**, the driver is placed into the body without direct contact to the gear tray.

The **gear tray**, made of white powder coated steel sheet according to **Zhaga** standards, is **integrated into the diffuser**. With 870-Farmer - depending on customer requirements - we can reach different levels of luminous flux from 3800 **up to 6600 lumen** with maximum **efficacy of 164 lm/W**. For more details please see technical data.

The injected **silicone gasket** with enhanced resistance ensures **maximum** chemical and weather **resistance** even under tough conditions. This endless foam sealing ensures the high IP protection up to IP67.



HIGHLIGHTED BENEFITS:

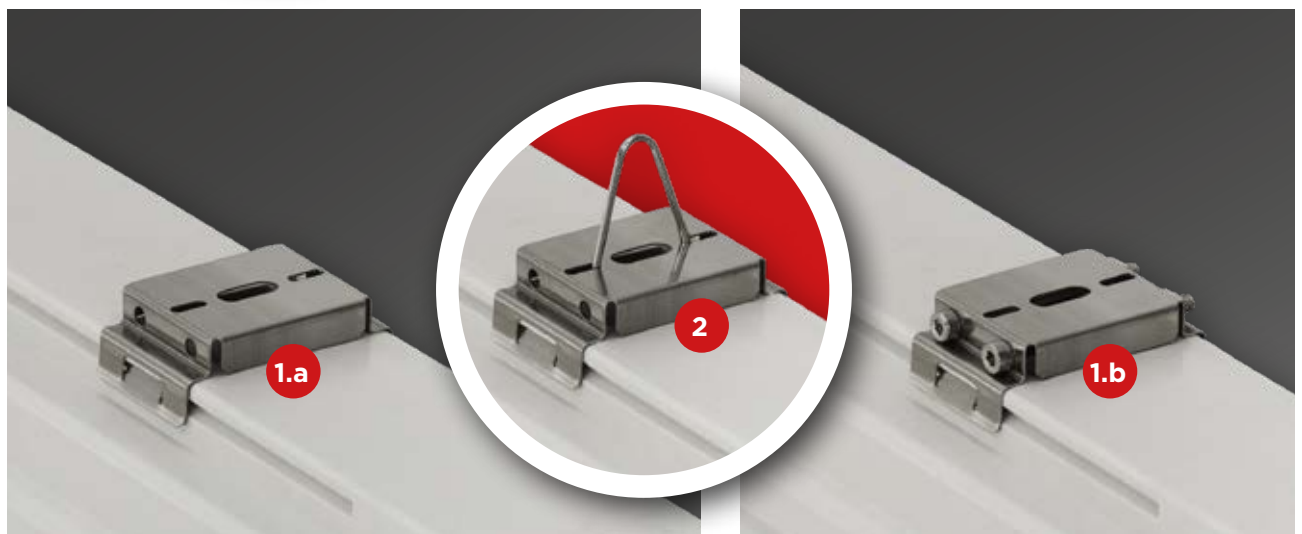

Ways of installing (options):

With **strengthened** (0,6 mm) stainless steel mounting brackets.

1.a They are easy-to-install onto the **ceiling or the wall** (in horizontal position).

1.b In case of vertical positioning, **special screws** keep the mounting brackets tight avoiding the luminaire from sliding.

2. **Suspension** on chains, wire ropes etc. with stainless steel mounting brackets and **with hooks**.
Easy installation: Adjustable distance of the mounting brackets (they can be positioned laterally on the housing)

Technical data (extract)

Products with a 3-year warranty	Power (W)	Luminare total luminous flux emitted (lm) PMMA	Lum. efficacy (lm/W) PMMA	CRI	Lifetime L70B50 (Ta=35°C)	Lifetime L80B10 (Ta=35°C)	A (mm)	B (mm)	Weight (kg)	EEI
---------------------------------	-----------	--	---------------------------	-----	---------------------------	---------------------------	--------	--------	-------------	-----

Lumnium3 Farmer HV (CCT: 4000K, on request other CCTs are available)

870 4ft (1200mm)	23	3800	164	>80	>72.000 h	>50.000 h	1174	700+/-76	2	D
870 5ft (1500mm)	33	5000	152	>80	>72.000 h	>50.000 h	1454	980+/-76	2,2	D
870 5ft (1500mm)	43	6600	154	>80	>72.000 h	>40.000 h	1454	980+/-76	2,2	D

Products with a 5-year warranty	Power (W)	Luminare total luminous flux emitted (lm) PMMA	Lum. efficacy (lm/W) PMMA	CRI	Lifetime L70B50 (Ta=35°C)	Lifetime L80B10 (Ta=35°C)	A (mm)	B (mm)	Weight (kg)	EEI
---------------------------------	-----------	--	---------------------------	-----	---------------------------	---------------------------	--------	--------	-------------	-----

Lumnium5 Farmer HV (CCT: 4000K, on request other CCTs are available)

870 4ft (1200mm)	23	3800	164	>80	>72.000 h	>50.000 h	1174	700+/-76	2	D
870 5ft (1500mm)	33	5000	152	>80	>72.000 h	>50.000 h	1454	980+/-76	2,2	D
870 5ft (1500mm)	43	6600	154	>80	>72.000 h	>40.000 h	1454	980+/-76	2,2	D



870-FARMER

Further options:



On request:



Schematic drawing with main dimensions

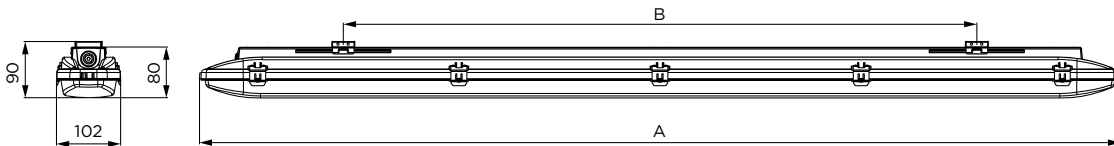

Photometric curves:

870-Farmer, 4ft (1200mm),
Lumnium Farmer HV, 23W, 3800lm,
PMMA

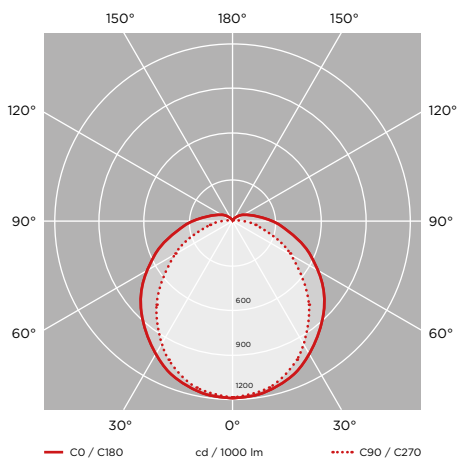

870-Farmer, 5ft (1500mm),
Lumnium Farmer HV, 43W, 6600lm,
PMMA

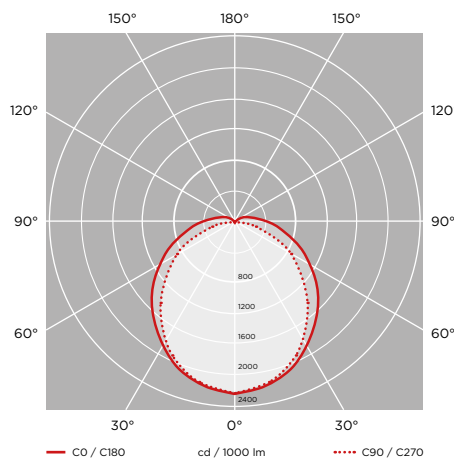

Luminaire customisation and the options of advanced controls are presented on page 5



771-FAVOURITE

Industrial dust and waterproof luminaires with LED modules

Now with a new, opalised diffuser with unique light transmissivity!
Specially developed for LED applications



FIELD OF APPLICATION:

Thanks to the construction principles of the gasket, the closing system and the diffuser our LED fixtures ensure a high grade of protection (IP65, IP66 or IP67) against dust, contamination and water permeation. In accordance with their IP grade they can be widely used to illuminate spaces with dusty and humid environment.

When using outdoors, the fittings should be protected against direct sunlight and adverse weather conditions. Under 0°C the application of a venting cable gland is necessary, as well as the silicone gasket is recommended.

TECHNICAL DESCRIPTION AND BENEFITS:

- **Housing:** It is made of flame retardant glass fibre reinforced polyester (on request suitable for 850°C glow wire test too), in light grey (RAL7035) colour. Glass fibre reinforced polyester has very good temperature resistance, mechanical stability. Furthermore, it is a good electrical insulator resisting the impacts of several chemicals and weather conditions. Its stability of size and shape at changing temperatures is excellent.
- **Diffuser:** Our LED luminaires with **opal** diffuser offer you:
 - **extremely high light efficiency** through high **light permeability, unique on the market**, (up to 93% light transmissivity)
 - an **excellent light uniformity** through **well-balanced light dispersing** (no shadows)
 - **elimination of the dazzling effect** (no glare)
 - **aesthetical appearance (no dots** of the single LEDs)
 - **keeping the usual, well-known features of the diffuser** such as chemical and heat resistance, mechanical features, **UV stabilization** etc.

Available in PC - injection moulded **Polycarbonate** (high mechanical strength and high heat and shock resistance) **or in Acrylic** - injection moulded **PMMA** (unique non-aging properties, high chemical resistance).

- The **gasket** between the diffuser and the housing is available in two versions:
 - **Injected endless silicone foam**
 - **Non-aging PU** (polyurethane) **endless foam**
- **Fixing the diffuser to the body:** with highly resistant clips made of **stainless steel** (standard or tamper-proof).
- **Gear tray** (reflector): White powder coated steel sheet according to **Zhaga** standards or customised.
- **Electrical components:** The adequate power supply is ensured through electronic driver, that is built into the luminaire.

LED

CE



771-FAVOURITE

IP65



Option:

IP66

IP67



Main technical options

Our opal diffuser has an **outstanding light transmissivity** up to **93%**. With this great light permeability, it is an **excellent choice for luminaires equipped with LED modules**.



771-FAVOURITE



The opal diffusers are made of UV stabilized **opalised** material, specially developed for LED applications. This ensures among others a well-balanced light distribution and the **elimination of glare**.

Usual stainless steel clips for **SELV** (Safety Extra Low Voltage) solutions.

The special tamper-proof stainless steel clips for **non-SELV (HV)** solutions can not be released with bare hands.



With 771-Favourite - depending on customer requirements - we can reach different levels of luminous flux (lumen) as well as luminous efficacy (lm/Watt). For more details please see technical data.



In order to optimise the thermal management of the luminaire we avoid the direct contact of the gear tray and driver, thus increasing the lifetime of the modules and driver.



LED Version with motion sensor

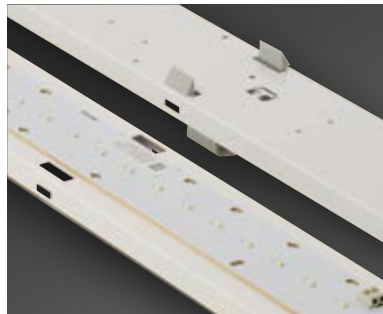

The gear tray is made of white powder coated steel sheet according to **Zhaga** standards. On request customisation possible.



Option: The **Rapid Connector** enables the electrical connection **without disassembling** the luminaire, thus **avoiding** a potential damage of the LED's inside the luminaire through **electrostatic discharge (ESD)**.



Light sources suffer from degradation in light output over time. The **CLO feature enables LED solutions to deliver constant lumen output through the life of the light engine.**

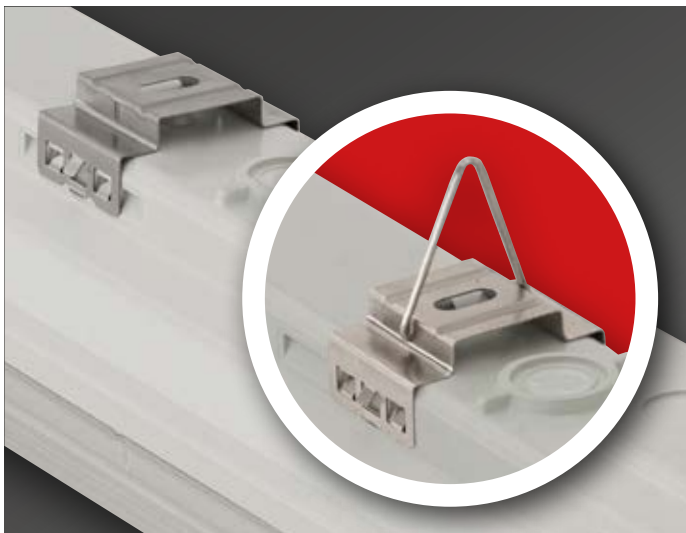

Ways of installing:

1. With stainless steel suspension brackets (easy-to-install) onto the ceiling.
2. Suspension on chains with stainless steel suspension brackets mounted with hooks.

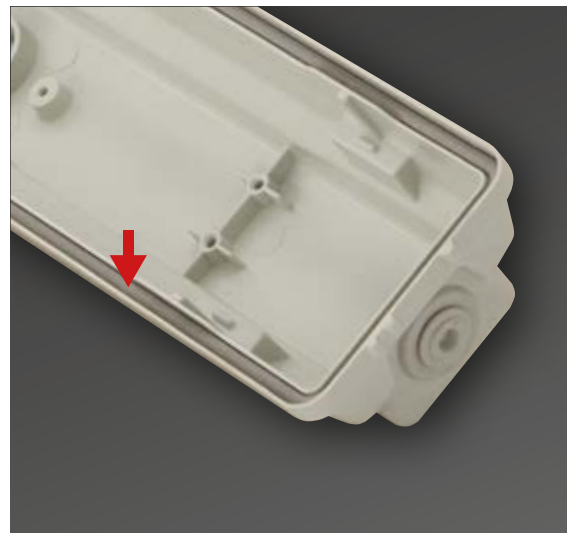

In order to ensure **maximum heat**, chemical and weather **resistance** even under tough conditions, the **gasket** between the diffuser and housing is made of **silicone** foam with enhanced resistance.



Technical data (extract)

Products with a 5-year warranty	Power (W)	Luminare total luminous flux - emitted (lm) PMMA	Lum. efficacy (lm/W) PMMA	CRI	Lifetime L70B50 (Ta=35°C)	Lifetime L80B10 (Ta=35°C)	A (mm)	B (mm)	Weight (kg)	EEL
---------------------------------	-----------	--	---------------------------	-----	---------------------------	---------------------------	--------	--------	-------------	-----

Lumnium EU with a DIP switch driver (CCT: 4000K, on request other CCTs are available)

771 2ft (600mm)	19/24	2700/3300	142	>80	>72.000 h	>72.000 h	669	460	0,9	D
771 4ft (1200mm)	21/25/29/35	3100/3800/4300/5000	143	>80	>72.000 h	>72.000 h	1277	800	2,2	D
771 5ft (1500mm)	24/31/37/44	3800/4700/5500/6300	143	>80	>72.000 h	>72.000 h	1577	1100	2,5	D
771 4ft (1200mm)	21/27/32/38	3300/4100/4800/5400	143	>80	>72.000 h	>72.000 h	1277	800	2,2	D
771 5ft (1500mm)	28/36/43/51	4500/5500/6300/7300	143	>80	>72.000 h	>72.000 h	1577	1100	2,5	D

Lumnium EU PRO with a DIP switch driver (CCT: 4000K, on request other CCTs are available)

771 4ft (1200mm)	20/25/31/36	3400/4100/5000/5700	158	>80	>102.000 h	>102.000 h	1277	800	2,2	C
771 5ft (1500mm)	21/26/32/37	3500/4400/5200/6000	162	>80	>102.000 h	>102.000 h	1577	1100	2,5	C
771 4ft (1200mm)	18/23/27/32	3100/3800/4500/5300	165	>80	>102.000 h	>102.000 h	1277	800	2,2	C
771 5ft (1500mm)	25/30/36/43	4200/5300/6300/7300	170	>80	>102.000 h	>102.000 h	1577	1100	2,5	C

Lumnium EU HF (CCT: 4000K, on request other CCTs are available)

771 4ft (2x1200mm)*	62	8600	138	>80	>72.000 h	>72.000 h	1277	800	2,65	D
771 5ft (2x1500mm)*	76	10800	140	>80	>72.000 h	>72.000 h	1577	1100	3	D

Philips Fortimo HV6 HF 3klm/ft (CCT: 4000K, on request other CCTs are available)

771 4ft (2x1200mm)*	66	10000	153	>80	>100.000 h	>64.000 h	1277	800	2,65	C
771 5ft (2x1500mm)*	83	12700	153	>80	>100.000 h	>64.000 h	1577	1100	3	C

Products with a 5-year warranty	Power (W)	Luminare total luminous flux - emitted (lm) PC	Lum. efficacy (lm/W) PC	CRI	Lifetime L70B50 (Ta=35°C)	Lifetime L80B10 (Ta=35°C)	A (mm)	B (mm)	Weight (kg)	EEL
---------------------------------	-----------	--	-------------------------	-----	---------------------------	---------------------------	--------	--------	-------------	-----

Lumnium EU with a DIP switch driver (CCT: 4000K, on request other CCTs are available)

771 2ft (600mm)	19/24	2500/3100	129	>80	>72.000 h	>72.000 h	669	460	0,9	D
771 4ft (1200mm)	21/25/29/35	2900/3600/4100/4800	137	>80	>72.000 h	>72.000 h	1277	800	2,2	D
771 5ft (1500mm)	24/31/37/44	3500/4500/5300/6000	136	>80	>72.000 h	>72.000 h	1577	1100	2,5	D
771 4ft (1200mm)	21/27/32/38	3100/3900/4600/5200	136	>80	>72.000 h	>72.000 h	1277	800	2,2	D
771 5ft (1500mm)	28/36/43/51	4300/5300/6100/7000	137	>80	>72.000 h	>72.000 h	1577	1100	2,5	D

Lumnium EU PRO with a DIP switch driver (CCT: 4000K, on request other CCTs are available)

771 4ft (1200mm)	20/25/31/36	3200/3900/4800/5500	152	>80	>102.000 h	>102.000 h	1277	800	2,2	C
771 5ft (1500mm)	21/26/32/37	3300/4200/5000/5700	154	>80	>102.000 h	>102.000 h	1577	1100	2,5	C
771 4ft (1200mm)	18/23/27/32	2900/3600/4300/5100	159	>80	>102.000 h	>102.000 h	1277	800	2,2	C
771 5ft (1500mm)	25/30/36/43	4000/5100/6100/7000	162	>80	>102.000 h	>102.000 h	1577	1100	2,5	C

Lumnium EU HF (CCT: 4000K, on request other CCTs are available)

771 4ft (2x1200mm)*	62	8100	130	>80	>72.000 h	>72.000 h	1277	800	2,65	D
771 5ft (2x1500mm)*	76	10200	134	>80	>72.000 h	>72.000 h	1577	1100	3	D

Philips Fortimo HV6 HF 3klm/ft (CCT: 4000K, on request other CCTs are available)

771 4ft (2x1200mm)*	66	9400	144	>80	>100.000 h	>64.000 h	1277	800	2,65	C
771 5ft (2x1500mm)*	83	12000	145	>80	>100.000 h	>64.000 h	1577	1100	3	C

* The LED strips are placed in one line in a twin (wider) housing.

771-FAVOURITE

Further options:



On request:



Schematic drawing with main dimensions

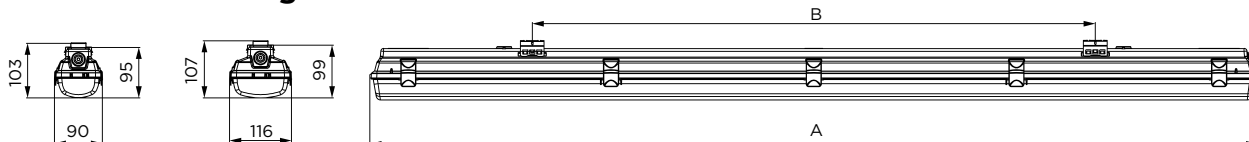

Photometric curves:

771-Favourite, 4ft (2x1200mm)*, Philips Fortimo LED strip HV6, 66W, 9400lm, PC

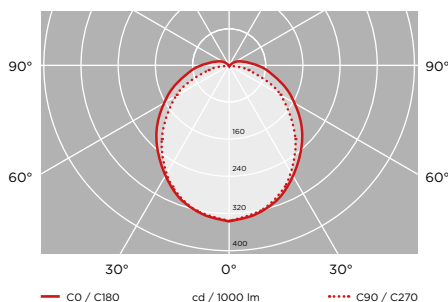

Photometric curves:

771-Favourite, 5ft (2x1500mm)*, Philips Fortimo LED Strip HV6, 83W, 12700lm, PMMA

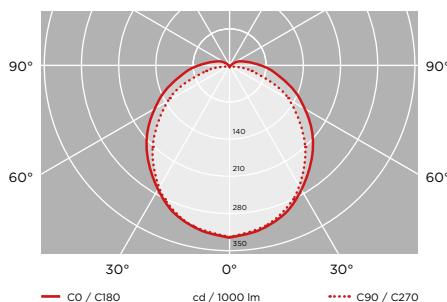

Luminaire customisation and the options of advanced controls are presented on page 5

771-ORIENT +50°C

Industrial dust and waterproof luminaires with LED modules

771-Orient is available in the following sizes: 1200mm, 1500mm. Available in IP65

YOUR MAIN BENEFITS:

A professional luminaire for wide usage, that fulfills the strongest quality requirements. Especially for applications where **high heat resistance (up to Ta +50°C)** is required.



FIELD OF APPLICATION:

Thanks to the construction principles of the gasket, the closing system and the diffuser our fixtures ensure a high grade of protection (IP65) against dust, contamination and water permeation. In accordance with their IP grade they can be used widely to illuminate spaces with dusty and humid environment. Thanks to its **enhanced heat resistance**, 771-Orient is especially suitable for applications, where **error-free functioning at higher ambient temperature** is desired.

When using outdoors, the fittings should be protected against direct sunlight and adverse weather conditions.

TECHNICAL DESCRIPTION AND BENEFITS:

■ **Housing:** It is made of flame retardant glass fibre reinforced polyester (on request suitable for 850°C glow wire test, too), in light grey (RAL 7035) colour. The glass fibre reinforced polyester has a very good temperature resistance and mechanical stability. Furthermore, it is a good electrical insulator resisting the impacts of several chemicals and weather conditions. Its stability of size and shape at changing temperatures is excellent.

■ The **diffuser** is available in injection moulded **opal polycarbonate (PC)** with extremely high light permeability and well-balanced light dispersing. Main advantages: High mechanical strength and high heat and shock resistance and excellent transparency.

The diffusers are designed with respect to their optical characteristics and are **UV resistant**.

■ In order to ensure maximum heat, chemical and weather resistance even under tough conditions, the gasket between the diffuser and housing is made of **silicone foam** with enhanced resistance.

■ **Fixing the diffuser to the body:** with highly resistant stainless steel clips

■ **Gear tray (reflector):** White powder coated steel sheet according to **Zhaga** standards or customised.

■ **Electrical components:** The adequate power supply is ensured with the electronic driver that is built into the luminaire.

LED

CE

771-ORIENT +50°C

IP65



Option:





Main technical options

Our new opal diffuser has an **outstanding light transmissivity of more than 90%**. With this great light permeability, it is an **excellent choice for luminaires equipped with LED modules**.



771-ORIENT +50°C



The opal diffusers are made of UV stabilized **opalised** material, specially developed for LED applications. This ensures among others a well-balanced light distribution and the **elimination of glare**.

Fixing of the diffuser to the body: With highly resistant stainless steel clips. Tamper-proof clips are available on request.

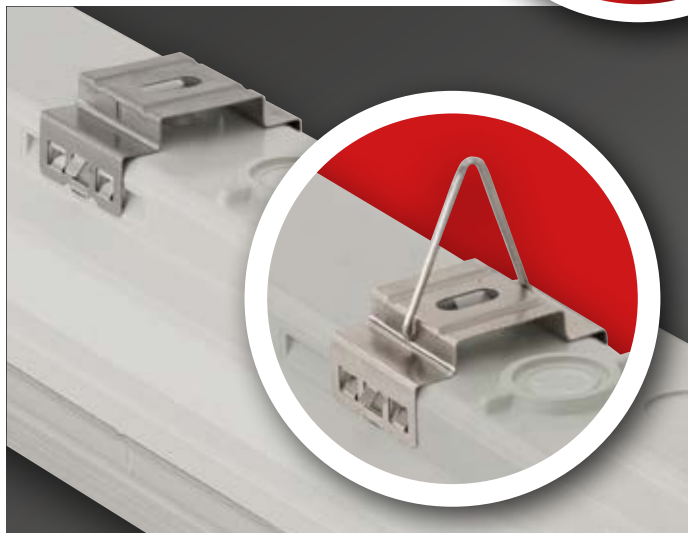

Ways of installing:

1. With stainless steel suspension brackets (easy-to-install) onto the ceiling.
2. Suspension on chains with stainless steel suspension brackets mounted with hooks.

Depending on customer requirements we can reach different levels of luminous flux (lumen) and high luminous efficacy (lm/Watt) of our LED luminaires. For more details please see technical data.



The gear tray is made of white powder coated steel sheet according to **Zhaga** standards. On request customisation possible.



Option: The **Rapid Connector** enables the electrical connection **without disassembling** the luminaire, thus **avoiding** a potential damage of the LED's inside the luminaire through **electrostatic discharge (ESD)**.

771-ORIENT +50°C



In order to optimise the thermal management of the luminaire at high ambient temperatures, the driver is fixated to the gear tray with a heat sink plate. Thus heat sensitive LED components function properly up to $T_a +50^\circ\text{C}$.



In order to ensure **maximum heat**, chemical and weather **resistance** even under tough conditions, the **gasket** between the diffuser and housing is made of **silicone** foam with enhanced resistance.



Technical data (extract)

Products with a 5-year warranty	Power (W)	Luminaire total luminous flux - emitted (lm) PC	Lum. efficacy (lm/W) PC	CRI	Lifetime L70B50 (Ta=50°C)	Lifetime L80B10 (Ta=50°C)	A (mm)	B (mm)	Weight (kg)	EEL
Philips Fortimo LV6 (CCT: 4000K, on request other CCTs are available)										
771 4ft (1200mm)	25	3800	152	>80	>70.000 h	>50.000 h	1277	800	2,2	C
771 5ft (1500mm)	31	4800	154	>80	>70.000 h	>50.000 h	1577	1100	2,5	C
771 5ft (2x1500mm)*	40	6100	152	>80	>70.000 h	>50.000 h	1577	1100	2,7	C
Philips Fortimo HV6 (CCT: 4000K, on request other CCTs are available)										
771 4ft (2x1200mm)*	56	7800	141	>80	>50.000 h	>50.000 h	1277	800	2,65	C
771 5ft (2x1500mm)*	70	9900	141	>80	>50.000 h	>50.000 h	1577	1100	3	C

* The LED strips are placed in one line in a twin (wider) housing.

771-ORIENT +50°C



Further options:



On request:



Schematic drawing with main dimensions

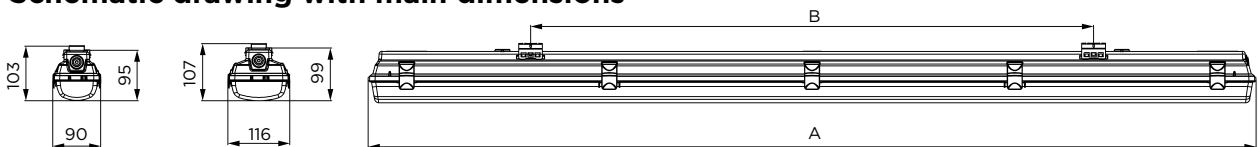

Photometric curves:

771-Orient +50°C, 4ft (1200mm), Philips Fortimo LED Strip LV6, 25W, 3800lm, PC

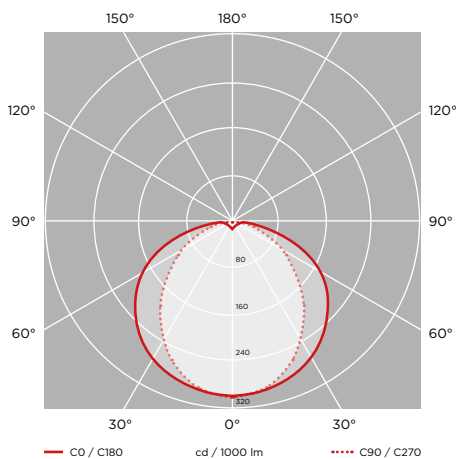

771-Orient +50°C, 5ft (2x1500mm)*, Philips Fortimo LED Strip HV6, 70W, 9900lm, PC

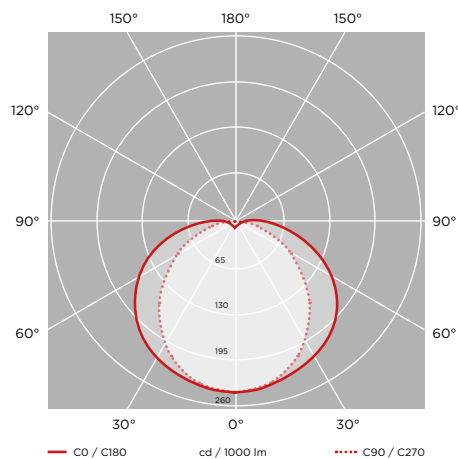

Luminaire customisation and the options of advanced controls are presented on page 5

771-EXTREME -30°C

Industrial dust and waterproof luminaires with LED modules for ambient temperature down to Ta -30 °C

With a new, opalised diffuser with unique light transmissivity! Specially developed for LED applications

YOUR MAIN BENEFITS:

The shape of 771-Favourite adapted for **extremely low (-30°C)** ambient temperatures.



FIELD OF APPLICATION:

Thanks to the construction principles of the gasket, the closing system and the diffuser our LED fixtures ensure a high grade of protection (IP65, IP66) against dust, contamination and water permeation even at extremely low ambient temperature. In accordance with their IP grade they can be widely used to illuminate spaces with dusty, humid environment down to Ta -30°C.

TECHNICAL DESCRIPTION AND BENEFITS:

- **Housing:** It is made of flame retardant glass fibre reinforced polyester (on request suitable for 850°C glow wire test, too), in light grey (RAL 7035) colour. The glass fibre reinforced polyester has a very good temperature resistance and mechanical stability. Furthermore, it is a good electrical insulator resisting the impacts of several chemicals and weather conditions. Its stability of size and shape at changing temperatures is excellent.
- **Diffuser:**
Available in PC - injection moulded **Polycarbonate**.
Main advantages: high mechanical strength and high heat and shock resistance
Our LED luminaires with opal diffuser offer you:
 - very good light efficiency through high light permeability, (up to 90% light transmissivity)
 - the usual, well-known features of the diffuser such as chemical and heat resistance, mechanical features, UV stabilization etc.
- In order to ensure maximum temperature, chemical and weather resistance even under tough conditions, the **gasket** between the diffuser and housing is made of **silicone** foam with enhanced durability.
- **Fixing of the diffuser to the body:** with highly resistant stainless steel clips (standard or tamper-proof version).
- **Gear tray (reflector):** White powder coated steel sheet according to **Zhaga** standards or customised.
- **Electrical components:** The adequate power supply is ensured with the electronic driver, that is built into the luminaire.

LED

CE

771-EXTREME -30°C

IP65



Option:

IP66





Main technical options



In order to ensure maximum heat, chemical and weather resistance even under tough conditions, the gasket between the diffuser and housing is made of silicone foam with enhanced durability.



Quick installation with stainless steel suspension brackets.



Comes with venting cable gland in order to prevent the build-up of moisture inside the luminaire thus avoiding its damage.

The opal diffusers are made of UV stabilized **opalised** material, specially developed for LED applications. This ensures among others a well-balanced light distribution and the elimination **of glare**.

771-EXTREME -30°C

Technical data (extract)

Products with a 5-year warranty	Power (W)	Luminaire total luminous flux - emitted (lm) PC	Lum. efficacy (lm/W) PC	CRI	Lifetime L70B50 (Ta=-35°C)	Lifetime L80B10 (Ta=-35°C)	A (mm)	B (mm)	Weight (kg)	EEI
Philips Fortimo LED Strip HV6										
771 4ft (2x1200mm)*	56	7800	141	>80	>100.000 h	>100.000 h	1277	800	2,65	C
771 5ft (2x1500mm)*	70	9900	141	>80	>100.000 h	>100.000 h	1577	1100	3	C

* The LED strips are placed in one line in a twin (wider) housing.

Further options:



On request:



Schematic drawing with main dimensions

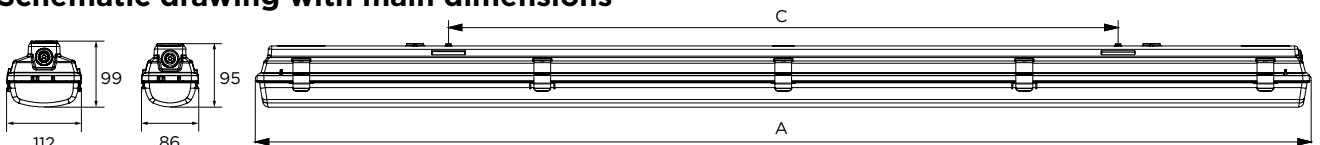

Photometric curves:

771-Extreme -30°C, 4ft (2x1200mm)*, Philips Fortimo LED HV6, 56W, 7800lm, PC

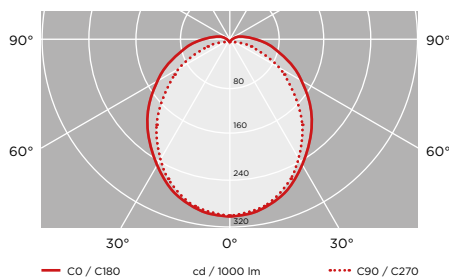

771-Extreme -30°C, 4ft (2x1500mm)*, Philips Fortimo LED HV6, 70W, 9900lm, PC

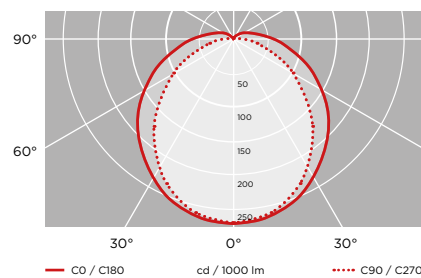

Luminaire customisation and the options of advanced controls are presented on page 5

771-VENTILA

Industrial dust and waterproof luminaires with LED modules

771-Ventila is available in the following sizes: 1x600mm, 1x1200mm, 1x1500mm, 2x600mm, 2x1200mm, 2x1500mm

YOUR MAIN BENEFITS:

A professional solution especially **for outdoor applications**. 771-Ventila withstands the impact of adverse weather conditions (sunlight, rain, wind etc.). $T_a = -20$ to $+35^\circ\text{C}$
Full range available in IP65 or IP66.



FIELD OF APPLICATION:

Thanks to the construction principles of the gasket, the closing system and the diffuser our fixtures ensure a high grade of protection (IP65, IP66) against dust, contamination and water permeation. In accordance with their IP grade they can be used widely to illuminate areas with dusty and humid environment.

Due to its **enhanced weather resistance**, 771-Ventila is especially suitable for applications, where **error-free functioning in outdoor conditions** is desired.

TECHNICAL DESCRIPTION AND BENEFITS:

- **Housing:** It is made of flame retardant glass fibre reinforced polyester (on request suitable for 850°C glow wire test, too), in light grey (RAL 7035) colour. The glass fibre reinforced polyester has a very good temperature resistance and mechanical stability. Furthermore, it is a good electrical insulator resisting the impacts of several chemicals and weather conditions. Its stability of size and shape at changing temperatures is excellent.
- The **diffuser** is available in injection moulded **opal acrylic (PMMA)** with extremely high light permeability, well-balanced light dispersing and **weather resistance**. The diffusers are designed with respect to their optical characteristics and are **UV resistant**.
- In order to ensure **maximum heat**, chemical and weather **resistance** even under tough conditions, the **gasket** between the diffuser and housing is made of **silicone foam** with enhanced durability.
- **Fixing of the diffuser to the body:** with highly resistant stainless steel clips (standard or tamper-proof version).
- **Gear tray (reflector):** White powder coated steel sheet according to **Zhaga** standards or customised.
- **Electrical components:** The adequate power supply is ensured with the electronic driver that is built into the luminaire.

LED

CE

771-VENTILA

IP65



Option:

IP66



Main technical options

Our opal diffuser has an **outstanding light transmissivity of more than 93%**. With this great light permeability, it is an **excellent choice for luminaires equipped with LED modules**.



The opal diffusers are made of UV stabilized **opalised** material, specially developed for LED applications. This ensures among others a well-balanced light distribution and the **elimination of glare**.

Fixing of the diffuser to the body: With highly resistant stainless steel clips. Tamper-proof clips are available on request.



The gear tray is made of white powder coated steel sheet according to **Zhaga** standards. On request customisation possible.



Depending on customer requirements we can reach different levels of luminous flux (lumen) and high luminous efficacy (lm/Watt) of our LED luminaires. For more details please see technical data.

In order to ensure **maximum** heat, chemical and **weather resistance** even under tough conditions, the **gasket** between the diffuser and housing is made of **silicone** foam with enhanced durability.



Comes with a **venting cable gland** in order to prevent the build-up of moisture inside the luminaire thus avoiding its damage.



Ways of installing:

1. In order to withstand the outdoor weather conditions (wind, storm), we recommend to use **strengthened** stainless steel suspension brackets. They are easy to install onto the **wall and ceiling**.
2. **Usual** suspension brackets, suitable for installation onto the **ceiling**, are available on request.



Technical data (extract)

Products with a 2-year warranty	Power (W)	Luminaire total luminous flux - emitted (lm) PMMA	Lum. efficacy (lm/W) PMMA	CRI	Lifetime L70B50 (Ta=35°C)	Lifetime L80B10 (Ta=35°C)	A (mm)	B (mm)	Weight (kg)	EEL
Lumnium EU with a DIP switch driver (CCT: 4000K, on request other CCTs are available)										
771 2ft (600mm)	19/24	2700/3300	142	>80	>72.000 h	>72.000 h	669	460	0,9	D
771 4ft (1200mm)	21/25/29/35	3100/3800/4300/5000	143	>80	>72.000 h	>72.000 h	1277	800	2,2	D
771 5ft (1500mm)	24/31/37/44	3800/4700/5500/6300	143	>80	>72.000 h	>72.000 h	1577	1100	2,5	D
771 4ft (1200mm)	21/27/32/38	3300/4100/4800/5400	143	>80	>72.000 h	>72.000 h	1277	800	2,2	D
771 5ft (1500mm)	28/36/43/51	4500/5500/6300/7300	143	>80	>72.000 h	>72.000 h	1577	1100	2,5	D
Lumnium EU PRO with a DIP switch driver (CCT: 4000K, on request other CCTs are available)										
771 4ft (1200mm)	20/25/31/36	3400/4100/5000/5700	158	>80	>102.000 h	>102.000 h	1277	800	2,2	C
771 5ft (1500mm)	21/26/32/37	3500/4400/5200/6000	162	>80	>102.000 h	>102.000 h	1577	1100	2,5	C
771 4ft (1200mm)	18/23/27/32	3100/3800/4500/5300	165	>80	>102.000 h	>102.000 h	1277	800	2,2	C
771 5ft (1500mm)	25/30/36/43	4200/5300/6300/7300	170	>80	>102.000 h	>102.000 h	1577	1100	2,5	C
Lumnium EU HF (CCT: 4000K, on request other CCTs are available)										
771 4ft (2x1200mm)*	62	8600	138	>80	>72.000 h	>72.000 h	1277	800	2,65	D
771 5ft (2x1500mm)*	76	10800	140	>80	>72.000 h	>72.000 h	1577	1100	3	D
Philips Fortimo HV6 (CCT: 4000K, on request other CCTs are available)										
771 4ft (2x1200mm)*	58	8900	153	>80	>100.000 h	>64.000 h	1277	800	2,65	C
771 5ft (2x1500mm)*	73	11300	154	>80	>100.000 h	>64.000 h	1577	1100	3	C
Philips Fortimo HV6 HF 3klm/ft (CCT: 4000K, on request other CCTs are available)										
771 4ft (2x1200mm)*	66	10000	153	>80	>100.000 h	>64.000 h	1277	800	2,65	C
771 5ft (2x1500mm)*	83	12700	153	>80	>100.000 h	>64.000 h	1577	1100	3	C

* The LED strips are placed in one line in a twin (wider) housing.

771-VENTILA

Further options:



On request:



Schematic drawing with main dimensions

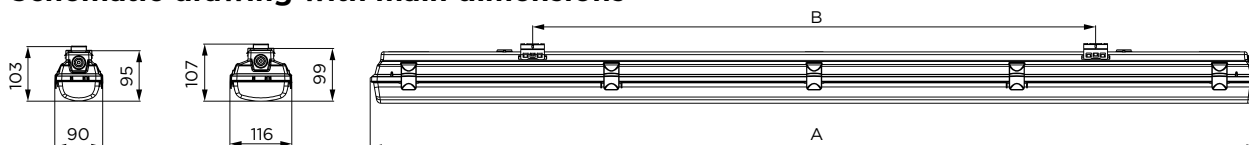

Photometric curves:

771-Ventila, 4ft (2x1200mm)*, Philips Fortimo LED Strip HV6, 56W, 8300lm, PMMA

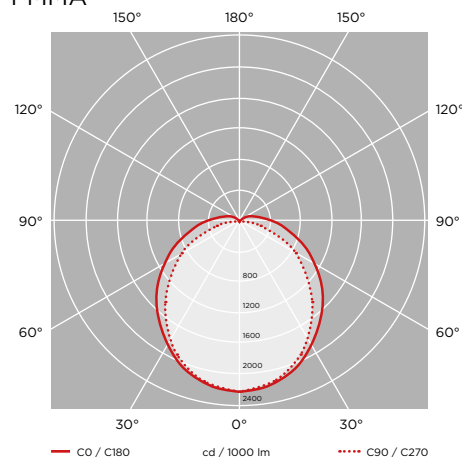

771-Ventila, 5ft (2x1500mm)*, Philips Fortimo LED Strip HV6, 70W, 10500lm, PMMA

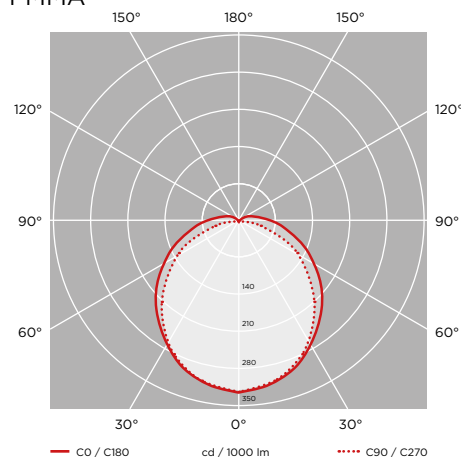

Luminaire customisation and the options of advanced controls are presented on page 5

771-FARMER

Industrial dust and waterproof luminaires with LED modules

Specially developed for farming industry and chemically aggressive environment!

YOUR MAIN BENEFITS:

Solution in high IP protection for **extremely harsh environment**. Heavily armed with special components for long-term **fight against chemicals**. Perfectly applicable in **agricultural industry**.



FIELD OF APPLICATION:

Thanks to the construction principles of the gasket, the closing system and the diffuser our LED fixtures ensure a high grade of protection (IP 65, IP 66) against dust, contamination and water permeation. In accordance with their IP grade and high chemical resistance they are especially recommended for buildings where animals are kept and also for harsh environmental rooms.

When using outdoors, the fittings should be protected against direct sunlight and adverse weather conditions. Under 0°C the application of a venting cable gland is necessary.

TECHNICAL DESCRIPTION AND BENEFITS:

- **Housing:** It is made of flame retardant glass-fibre reinforced polyester, in light grey (RAL7035) colour. The glass fibre reinforced polyester has a very good temperature resistance and mechanical stability. Furthermore, it is a good electrical insulator resisting the impacts of several chemicals and weather conditions. Its stability of size and shape at changing temperatures is excellent.
- **Diffuser:** The diffuser is available in **injection moulded opal acrylic (PMMA)** with unique **non-aging** properties and **extremely high chemical resistance**.
- Our LED-luminaires with **opal** diffuser offer you:
 - **extremely high light transmissivity** (up to 93%) **unique on the market**
 - **homogenous, well-balanced light** (no shadows)
- **Gasket:** **Injected endless silicone foam** with enhanced resistance
- **Fixing the diffuser to the body:** with highly resistant **tamper-proof clips made of stainless steel**
- **Gear tray** (reflector): white powder coated steel sheet according to **Zhaga** standards or customised
- **Electrical components:** The adequate power supply is ensured through a special **hermetically sealed electronic driver - LUMNIUM Farmer HV**.

LED



CE

771-FARMER

IP65



Option:

IP66



Main technical options

Our new opal diffuser has an **outstanding light transmissivity up to 93%**. Thanks to the wide beam angle, **homogenous illumination** even at low height of luminaire.



771-FARMER

The **maximum of chemical resistance** achieved by using **special components**:

Tinned wires

Hermetically sealed driver

Corrosion resistant LED system, LUMNIUM Farmer HV, designed for long-term resistance against chemicals, especially ammonia.

Strengthened suspension brackets made of stainless steel

1

2



Ways of installing (options):

1. With stainless steel suspension brackets (easy-to-install) onto the ceiling.
2. Suspension on chains with stainless steel suspension brackets mounted with hooks.

Endless silicone foam as sealing with enhanced resistance and extreme durability

Technical data (extract)

Products with a 3-year warranty	Power (W)	Luminaire total luminous flux emitted (lm) PMMA	Lum. efficacy (lm/W) PMMA	CRI	Lifetime L70B50 (Ta=35°C)	Lifetime L80B10 (Ta=35°C)	A (mm)	B (mm)	Weight (kg)	EEI
---------------------------------	-----------	---	---------------------------	-----	---------------------------	---------------------------	--------	--------	-------------	-----

Lumnium3 Farmer HV (CCT: 4000K, on request other CCTs are available)

771 2ft (600 mm)	27	3800	140	>80	>72.000 h	>50.000 h	669	460	1,2	D
771 4ft (1200mm)	23	3800	164	>80	>72.000 h	>50.000 h	1277	800	2	D
771 5ft (1500mm)	33	5000	152	>80	>72.000 h	>50.000 h	1577	1100	2,2	D
771 5ft (2x1500mm)*	43	6600	154	>80	>72.000 h	>40.000 h	1577	1100	2,2	D

Products with a 5-year warranty	Power (W)	Luminaire total luminous flux emitted (lm) PMMA	Lum. efficacy (lm/W) PMMA	CRI	Lifetime L70B50 (Ta=35°C)	Lifetime L80B10 (Ta=35°C)	A (mm)	B (mm)	Weight (kg)	EEI
---------------------------------	-----------	---	---------------------------	-----	---------------------------	---------------------------	--------	--------	-------------	-----

Lumnium5 Farmer HV (CCT: 4000K, on request other CCTs are available)

771 2ft (600mm)	27	3800	140	>80	>72.000 h	>50.000 h	669	460	1,2	D
771 4ft (1200mm)	23	3800	164	>80	>72.000 h	>50.000 h	1277	800	2	D
771 5ft (1500mm)	33	5000	152	>80	>72.000 h	>50.000 h	1577	1100	2,2	D
771 5ft (2x1500mm)*	43	6600	154	>80	>72.000 h	>40.000 h	1577	1100	2,2	D

* The LED strips are placed in one line in a twin (wider) housing.

Further options:



On request:



Schematic drawing with main dimensions

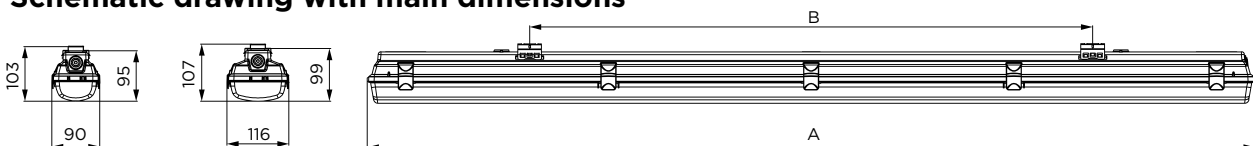

Photometric curves:

771-Farmer, 4ft (1x1200m),
Lumnium Farmer HV, 23W, 3800lm,
PMMA

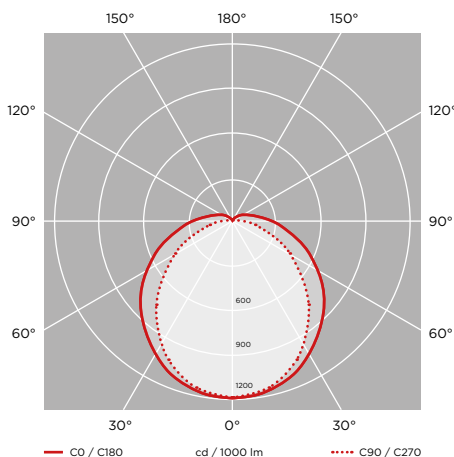

771-Farmer, 5ft (2x1500mm)*,
Lumnium Farmer HV, 43W, 6600lm,
PMMA

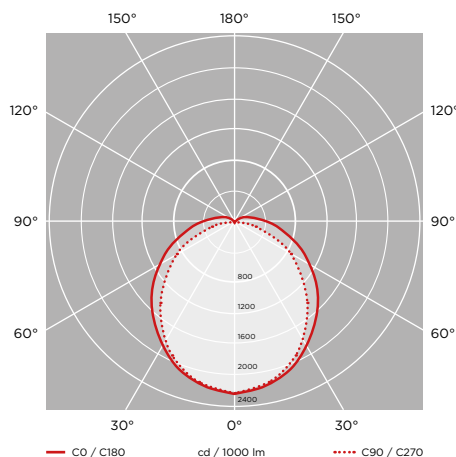

Luminaire customisation and the options of advanced controls are presented on page 5



775-PC

Industrial dust and waterproof luminaires

Equipped with **LED modules**. 775-PC is available in the following sizes: 2x600mm, 1x1200mm, 1x1500mm, 2x1200mm, 2x1500mm

YOUR MAIN BENEFITS:

A professional luminaire for wide usage, that fulfils the strongest quality requirements. Especially for applications, where **high impact resistance (IK rating)** is required. Available in IP65 (or optionally also IP66 or IP67).



775-PC



IP65



Option:

IP66

IP67



3F



FIELD OF APPLICATION:

Due to the construction principles of the gasket, the closing system and the diffuser our fixtures ensure a high grade of protection (IP65 or IP66) against dust, contamination and water permeation. (Optionally available in IP67). In accordance with their IP-grade they can be used widely to illuminate spaces with dusty and humid environment. Thanks to its **enhanced impact resistance**, 775-PC is especially suitable for applications, where **a high IK impact rating** is required.

When using outdoors, the fittings should be protected against direct sunlight and adverse weather conditions. Under 0°C the application of a venting cable gland is necessary, as well as the silicone gasket is recommended.

TECHNICAL DESCRIPTION AND BENEFITS:

- **Housing:** It is made of flame retardant **injection moulded polycarbonate (PC)** (suitable for 850°C glow wire test), in light grey (RAL7035) colour. This material has very high mechanical strength and allows us to reach an excellent shock resistance.
- The **diffuser** is available in the following versions: Injection moulded polycarbonate (**PC**), **opal**, with a shock resistance of IK10, with extremely high light permeability and well-balanced light dispersing. As option injection moulded acrylic (PMMA) diffuser in opal version is available. The diffusers are designed with respect to their optical characteristics and are **UV resistant**.
- The **gasket** between the diffuser and the housing is available in two versions:
 - **Injected endless silicone foam**
 - **Non-aging PU (polyurethane) endless foam**
- **Fixing of the diffuser to the body:** with highly resistant clips made of **stainless steel** (standard or tamper-proof).
- **Gear tray (reflector):** White powder coated steel sheet according to **Zhaga** standards or customised.
- **Electrical components:** The adequate power supply is ensured with the electronic driver, that is built into the luminaire.

Main technical options

Our new opal diffuser has an **outstanding light transmissivity of more than 90%**. With this great light permeability, it is an **excellent choice for luminaires equipped with LED modules**.



LED

The opal diffusers are made of UV stabilized **opalised** material, specially developed for LED applications. This ensures among others a well-balanced light distribution and the **elimination of glare**. Moreover the diffuser made of injection moulded polycarbonate (PC) excels at highest **impact resistance of IK10**.

775-PC

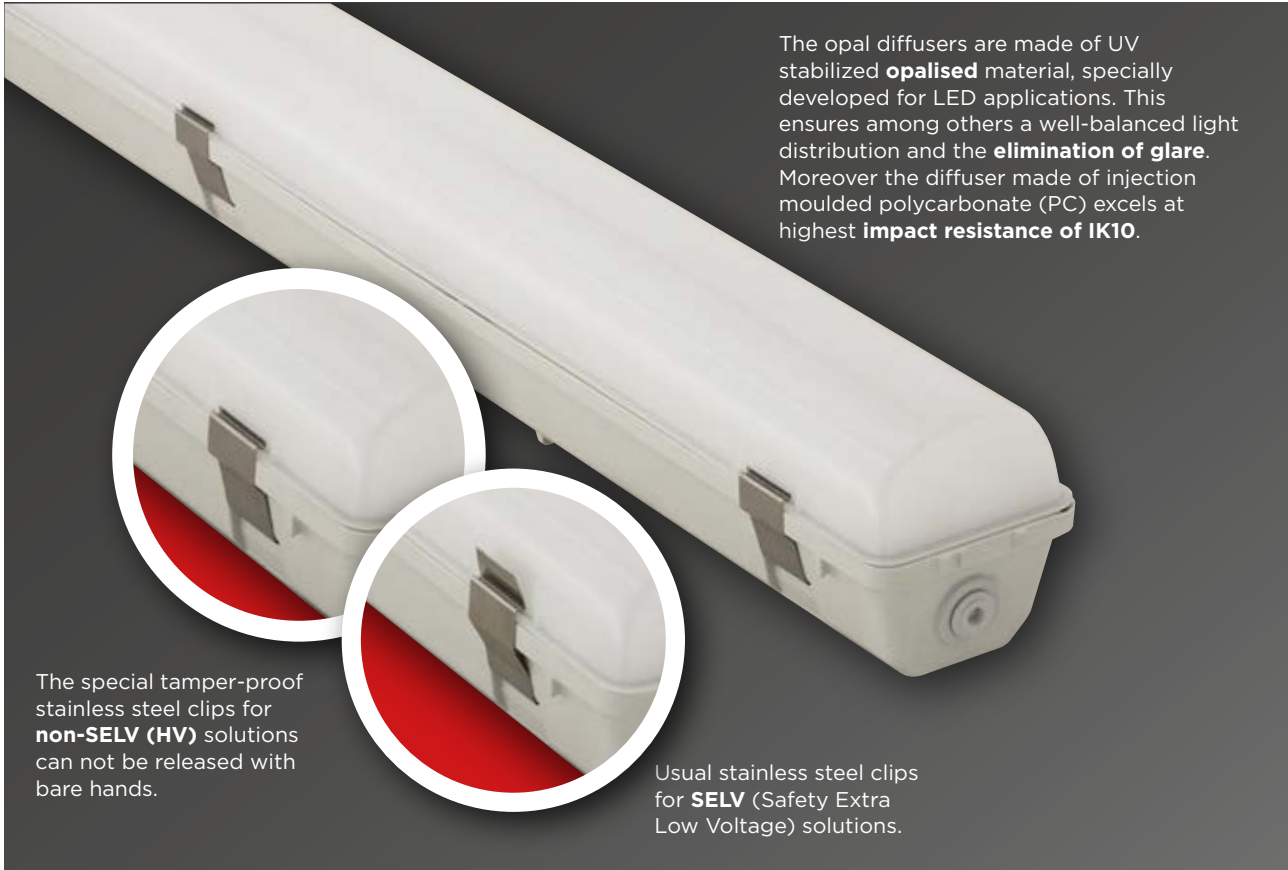

The special tamper-proof stainless steel clips for **non-SELV (HV)** solutions can not be released with bare hands.

Usual stainless steel clips for **SELV** (Safety Extra Low Voltage) solutions.

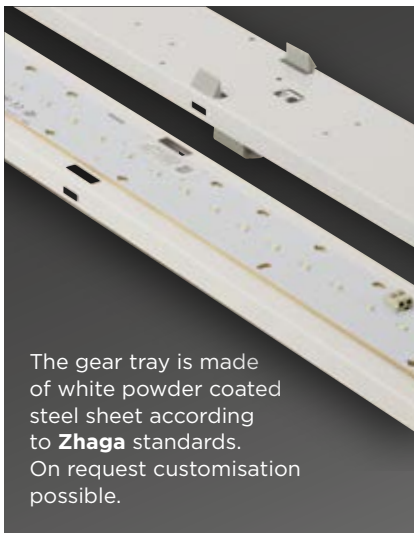

The gear tray is made of white powder coated steel sheet according to **Zhaga** standards. On request customisation possible.



Ways of installing:

1. With stainless steel suspension brackets (easy-to-install) onto the ceiling.

2. Suspension on chains with stainless steel suspension brackets mounted with hooks.

In order to ensure **maximum heat**, chemical and weather **resistance** even under tough conditions, the **gasket** between the diffuser and housing is made of **silicone** foam with enhanced resistance.

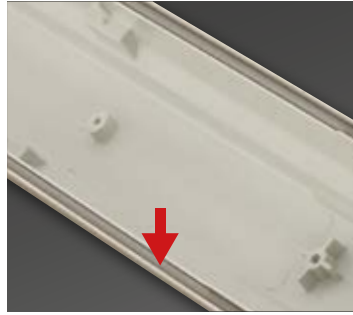

775-PC with motion sensor

CLO

Light sources suffer from degradation in light output over time. **The CLO feature enables LED solutions to deliver constant lumen output through the life of the light engine.**



Further accessories:
 1. cable gland
 Different connectors enabling the electrical connection **without disassembling** the luminaire, thus **avoiding** a potential damage of the LED's inside the luminaire through **electrostatic discharge (ESD)**.
 2. rapid connector
 3. circular connector system

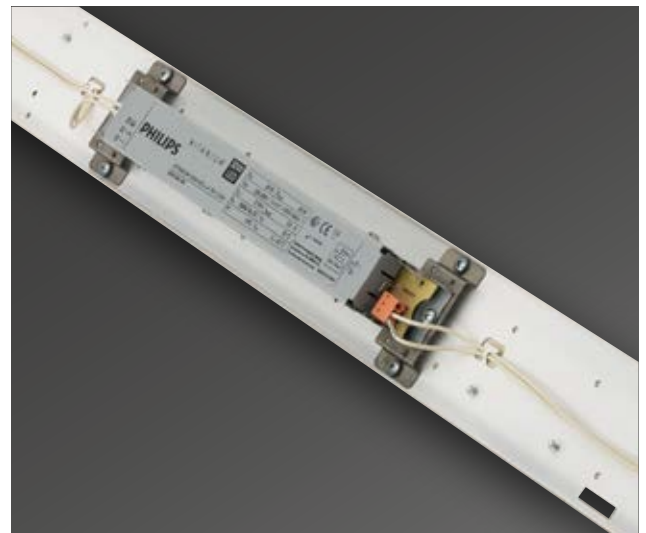

Depending on customer requirements we can reach different levels of luminous flux (lumen) as well as luminous efficacy (lm/Watt) of our LED luminaires. For more details please see technical data.

In order to optimise the thermal management of the luminaire we avoid the direct contact of the gear tray and driver, thus increasing the lifetime of the modules and driver.



Technical data (extract)

Products with a 5-year warranty	Power (W)	Luminaire total luminous flux - emitted (lm) PMMA	Lum. efficacy (lm/W) PMMA	CRI	Lifetime L70B50 (Ta=35°C)	Lifetime L80B10 (Ta=35°C)	A (mm)	B (mm)	Weight (kg)	EEI
---------------------------------	-----------	---	---------------------------	-----	---------------------------	---------------------------	--------	--------	-------------	-----

Lumnium EU with a DIP switch driver (CCT: 4000K, on request other CCTs are available)

775 2ft (600mm)	19/24	2700/3300	142	>80	>72.000 h	>72.000 h	669	460	0,9	D
775 4ft (1200mm)	21/25/29/35	3100/3800/4300/5000	143	>80	>72.000 h	>72.000 h	1277	800	2,2	D
775 5ft (1500mm)	24/31/37/44	3800/4700/5500/6300	143	>80	>72.000 h	>72.000 h	1577	1100	2,5	D
775 4ft (1200mm)	21/27/32/38	3300/4100/4800/5400	143	>80	>72.000 h	>72.000 h	1277	800	2,2	D
775 5ft (1500mm)	28/36/43/51	4500/5500/6300/7300	143	>80	>72.000 h	>72.000 h	1577	1100	2,5	D

Lumnium EU PRO with a DIP switch driver (CCT: 4000K, on request other CCTs are available)

775 4ft (1200mm)	20/25/31/36	3400/4100/5000/5700	158	>80	>102.000 h	>102.000 h	1277	800	2,2	C
775 5ft (1500mm)	21/26/32/37	3500/4400/5200/6000	162	>80	>102.000 h	>102.000 h	1577	1100	2,5	C
775 4ft (1200mm)	18/23/27/32	3100/3800/4500/5300	165	>80	>102.000 h	>102.000 h	1277	800	2,2	C
775 5ft (1500mm)	25/30/36/43	4200/5300/6300/7300	170	>80	>102.000 h	>102.000 h	1577	1100	2,5	C

Lumnium EU HF (CCT: 4000K, on request other CCTs are available)

775 4ft (2x1200mm)*	62	8600	138	>80	>72.000 h	>72.000 h	1277	800	2,65	D
775 5ft (2x1500mm)*	76	10800	140	>80	>72.000 h	>72.000 h	1577	1100	3	D

Philips Fortimo HV6 HF 3klm/ft (CCT: 4000K, on request other CCTs are available)

775 4ft (2x1200mm)*	66	10000	153	>80	>100.000 h	>64.000 h	1277	800	2,65	C
775 5ft (2x1500mm)*	83	12700	153	>80	>100.000 h	>64.000 h	1577	1100	3	C

Products with a 5-year warranty	Power (W)	Luminaire total luminous flux - emitted (lm) PC	Lum. efficacy (lm/W) PC	CRI	Lifetime L70B50 (Ta=35°C)	Lifetime L80B10 (Ta=35°C)	A (mm)	B (mm)	Weight (kg)	EEI
---------------------------------	-----------	---	-------------------------	-----	---------------------------	---------------------------	--------	--------	-------------	-----

Lumnium EU with a DIP switch driver (CCT: 4000K, on request other CCTs are available)

775 2ft (600mm)	19/24	2500/3100	129	>80	>72.000 h	>72.000 h	669	460	0,9	D
775 4ft (1200mm)	21/25/29/35	2900/3600/4100/4800	137	>80	>72.000 h	>72.000 h	1277	800	2,2	D
775 5ft (1500mm)	24/31/37/44	3500/4500/5300/6000	136	>80	>72.000 h	>72.000 h	1577	1100	2,5	D
775 4ft (1200mm)	21/27/32/38	3100/3900/4600/5200	136	>80	>72.000 h	>72.000 h	1277	800	2,2	D
775 5ft (1500mm)	28/36/43/51	4300/5300/6100/7000	137	>80	>72.000 h	>72.000 h	1577	1100	2,5	D

Lumnium EU PRO with a DIP switch driver (CCT: 4000K, on request other CCTs are available)

775 4ft (1200mm)	20/25/31/36	3200/3900/4800/5500	152	>80	>102.000 h	>102.000 h	1277	800	2,2	C
775 5ft (1500mm)	21/26/32/37	3300/4200/5000/5700	154	>80	>102.000 h	>102.000 h	1577	1100	2,5	C
775 4ft (1200mm)	18/23/27/32	2900/3600/4300/5100	159	>80	>102.000 h	>102.000 h	1277	800	2,2	C
775 5ft (1500mm)	25/30/36/43	4000/5100/6100/7000	162	>80	>102.000 h	>102.000 h	1577	1100	2,5	C

Lumnium EU HF (CCT: 4000K, on request other CCTs are available)

775 4ft (2x1200mm)*	62	8100	130	>80	>72.000 h	>72.000 h	1277	800	2,65	D
775 5ft (2x1500mm)*	76	10200	134	>80	>72.000 h	>72.000 h	1577	1100	3	D

Philips Fortimo HV6 HF 3klm/ft (CCT: 4000K, on request other CCTs are available)

775 4ft (2x1200mm)*	66	9400	144	>80	>100.000 h	>64.000 h	1277	800	2,65	C
775 5ft (2x1500mm)*	83	12000	145	>80	>100.000 h	>64.000 h	1577	1100	3	C

* The LED strips are placed in one line in a twin (wider) housing.

Further options:

On request:



Schematic drawing with main dimensions

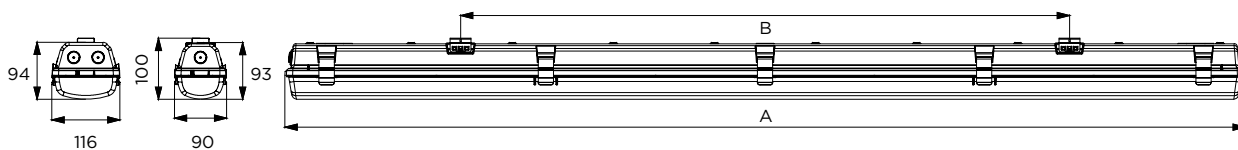

Photometric curves:

775-PC, 4ft (2x1200mm)*, Philips Fortimo LED Strip HV6, 66W, 10000lm, PMMA

775-PC, 4ft (2x1500mm)*, Philips Fortimo LED Strip HV6, 83W, 12000lm, PC

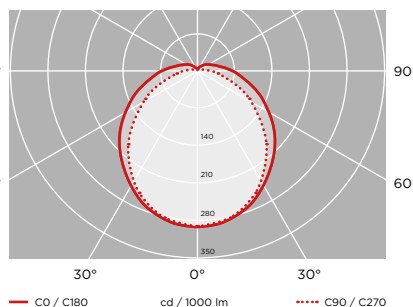
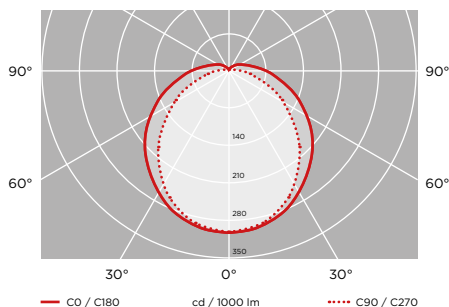

Luminaire customisation and the options of advanced controls are presented on page 5



Kinyomási elágazás B



793-MULTIPROOF

Professional dust and waterproof extruded luminaires with LED modules.

For diverse industrial areas! (farming or food and outdoor)

YOUR MAIN BENEFITS:

The luminaires fulfil the requirements of food law (HACCP) - highly resistant against several detergents and chemicals - also withstanding the high-pressure jet water (on request IP69)



FIELD OF APPLICATION:

Due to the construction principles of the extruded profile and the end caps, our LED fixtures ensure a **high grade of protection (IP66, IP67, IP69)** against dust, contamination and water permeation. In accordance with their IP grade, they can be widely used to illuminate spaces with dusty, humid environment.

Thanks to its enhanced weather and chemical resistance, 793-Multiproof is extremely versatile and suitable for a plenty of applications where errorfree functioning is desired.

The co-extruded PMMA profile allows us **placement in farming industry or in food-processing industry and in outdoor areas.**

TECHNICAL DESCRIPTION AND BENEFITS:

- **Housing:** Made of **Acrylic (PMMA)** by **co-extrusion**, in white (RAL 9010) colour. The optical diffusing (upper) part is opalised. Thanks to the **strengthened Acrylic** raw material used, the whole fitting shows very high mechanical strength and **high heat and shock resistance** (\geq IK08). At the same time further main advantages of the PMMA also apply such as **weather, chemical and UV resistance.**
- The **co-extruded opal** diffuser offers you:
 - **high light transmissivity** (up to 89%)
 - **homogenous, well-balanced light dispersing** (no shadows)
 - **elimination of the dazzling effect** (no glare)
 - **unique appearance and clean impression (no clips, no dots** of the single LED's)
- **End caps:** Made of impact resistant polyamide and glued to the body
- **Gear tray** (reflector): White powder coated steel sheet according to **Zhaga** standards or customized.
- **Electrical components:** The adequate power supply is ensured through electronic driver, that is built into the luminaire.

LED

CE

HACCP

793-MULTIPROOF

IP66



Option:

IP67

IP69



1F

3F



Main technical options

The gear tray is made of white powder coated steel sheet according to **Zhaga** standards.



793-MULTIPROOF

1,5 min
INSTALLATION TIME

The diffusing part of the co-extruded PMMA profile is made of UV stabilized, **opalized** material ensuring well-balanced light distribution and the elimination of glare. **The light angle is adjustable** thanks to the freely **rotatable tube** in the clamps (no shadows).

Ways of installing: With stainless steel **mounting clamps**. They are easy to install onto the **wall or ceiling**. The clamps can be positioned freely on the fixture thus the tube is freely rotatable.

Quick installation: thanks to the application of **rapid connector** (Adels, Stucchi, Wieland), the electrical connection is fast and easy even without disassembling the luminaire. **Your benefits:** significant **cost savings and increased competitiveness** on the market.



In food industry and outdoor areas: thanks to the **venting plug** the condensation of the humidity inside the luminaire can be **avoided**.



In farmer industry: the luminaire is equipped with special chemically-resistant electronic components (LED modules with protective layer, hermetically sealed driver, tinned cables, Adels rapid connector)

The glued end caps are locked up hermetically ensuring the **high IP protection** (up to IP69).

Technical data (extract)



Products with a 5-year warranty	Power (W)	Luminaire total luminous flux - emitted (lm) PMMA	Lum. efficacy (lm/W) PMMA	CRI	Lifetime L70B50 (Ta=35°C)	Lifetime L80B10 (Ta=35°C)	A (mm)	B (mm)	Weight (kg)	EEL
---------------------------------	-----------	---	---------------------------	-----	---------------------------	---------------------------	--------	--------	-------------	-----

Lumnium EU (CCT: 4000K, on request other CCTs are available)

793 2ft (600mm)	24	3200	133	>80	>72 000 h	>72 000 h	602	400	0,91	D
793 4ft (1200mm)	24	3400	144	>80	>72 000 h	>72 000 h	1164	775	1,49	D
793 5ft (1500mm)	30	4200	140	>80	>72 000 h	>72 000 h	1462	975	1,79	D
793 4ft (1200mm)	37	5000	133	>80	>72 000 h	>72 000 h	1164	775	1,49	D
793 5ft (1500mm)	51	6700	134	>80	>72 000 h	>72 000 h	1462	975	1,79	D

Lumnium EU PRO (CCT: 4000K, on request other CCTs are available)

793 4ft (1200mm)	22	3150	143	>80	>72 000 h	>72 000 h	1164	775	1,49	C
793 5ft (1500mm)	27	3900	146	>80	>72 000 h	>72 000 h	1462	975	1,79	C
793 4ft (1200mm)	32	4600	149	>80	>72 000 h	>72 000 h	1164	775	1,49	C
793 5ft (1500mm)	41	6300	154	>80	>72 000 h	>72 000 h	1462	975	1,79	C

793-MULTIPROOF

Further options:



On request:



Schematic drawing with main dimensions

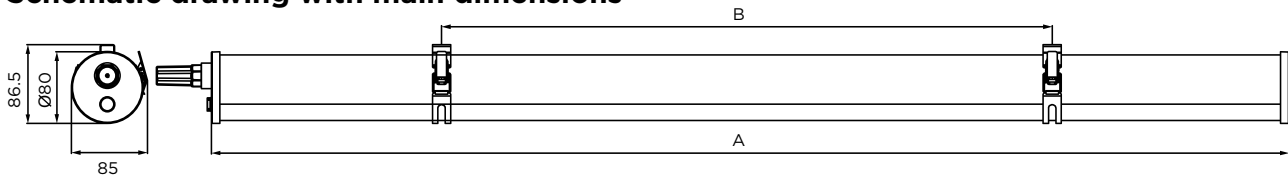

Photometric curves:

793-Multiproof, 5ft (1500mm), Lumnium EU, 51W, 6700lm

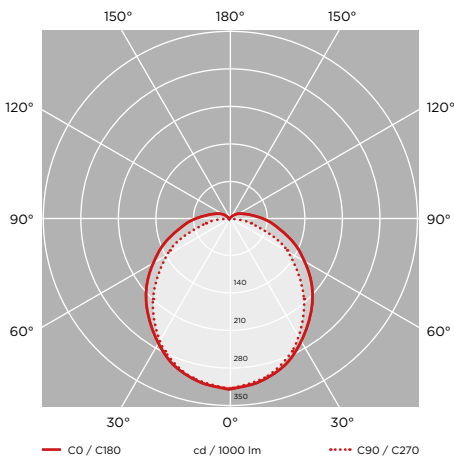

793-Multiproof, 5ft (1500mm), Lumnium EU PRO, 41W, 6300lm

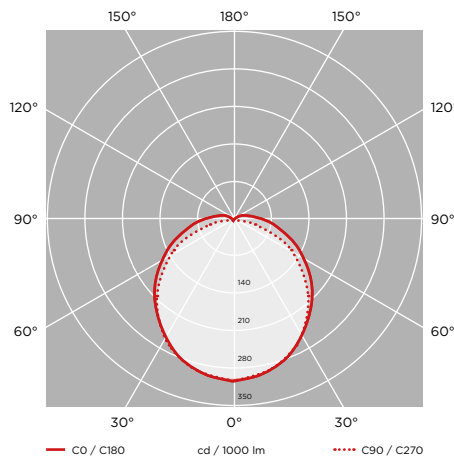

Luminaire customisation and the options of advanced controls are presented on page 5

SAFE-EX

Explosion-proof, industrial dust and waterproof luminaires with LED modules.

Suitable for environment with risk of explosion.

YOUR MAIN BENEFITS:

Permitted to be applied in Ex Zone 2, 22 areas

Robust construction, excellent impact resistance (7J)



SAFE-EX



IP66



Option:



FIELD OF APPLICATION:

The light fitting is suitable for environments with a danger of explosion of gas, dust, and combustible fumes: explosion hazardous locations (power plants, factories, mills, army facilities, plants for processing of gases and oil ... etc.)

Thanks to the construction principles of the gasket, the closing system and the diffuser, our fixtures ensure a high grade of protection (IP66) against dust, contamination and water permeation. In accordance with their IP rating they can be widely used to illuminate dusty and humid areas with a risk of explosion both indoor and outdoor.

TECHNICAL DESCRIPTION AND BENEFITS:

- **Housing:** It is made of flame retardant **GRP** - glass fibre reinforced polyester, suitable for 850°C glow wire test, in light grey (RAL7035) colour. The glass fibre reinforced polyester is resistant to heat and has an outstanding mechanical stability. Furthermore, it is a good electrical insulator resisting the impacts of several chemicals and weather conditions. Its stability of size and shape at changing temperatures is excellent.
- **Diffuser: Available in PC** - injection moulded **opalised Polycarbonate** (high mechanical strength and high heat and shock resistance)
- The **gasket** between the diffuser and the housing is available in:
 - **Non-aging Injected silicone endless foam**
- **Fixing the diffuser to the body:** With stainless steel clips.
- **Gear tray (reflector):** White powder coated steel sheet.
- **Electrical components:** High end certified electrical components designed for LED technology. For more details, please see technical data.

Further benefits:

- Low surface temperature
- No flicker, no eye disturbance, no UV radiation
- Trouble-proof operation even at extreme ambient temperature
- Maintenance-free
- Weatherproof, tamper-proof, UV stable fixture

■ Certified with protection levels:

- II 3 G Ex ec IIC T5 Gc
- II 3 D Ex tc IIIC T70°C Dc

Main technical options

Our **opalised** diffuser made of UV-stabilized material achieves **high efficacy (up to 155 lm/W)** emitted from the luminaire. On request transparent diffuser is available.



LED

With SAFE-EX - depending on customer requirements - we can reach different levels of luminous flux **from 2500 up to 6500 lumen** with maximum efficacy of 155 lm/W. For more details please see technical data.

SAFE-EX



Labour cost-saving **fast installation** (no screwed clips). They can be opened with the proper tool only in accordance with the EU directive



Up to **3 cable glands M25** for easy installation



No loose parts: diffuser and gear tray are secured to the body



Robust construction, excellent **impact resistance (7J)**

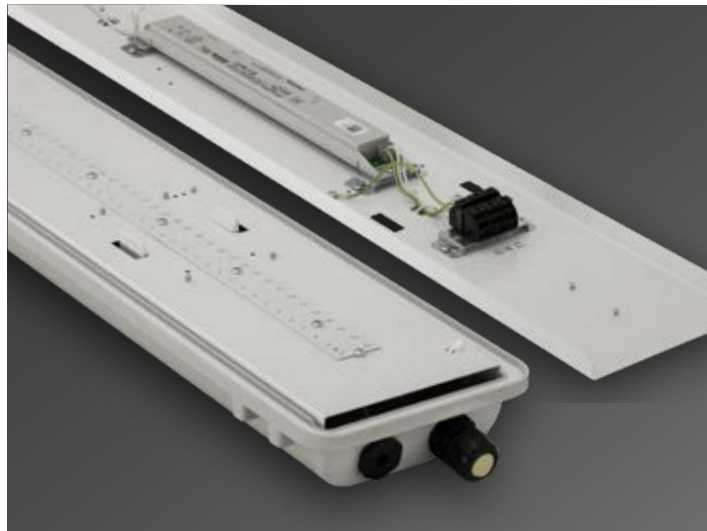

In order to optimize the thermal management and the error free functioning even under tough conditions **branded components** have been selected

The injected **silicone gasket** with enhanced resistance ensures a **maximum** chemical and weather **resistance** even under tough conditions. This endless foam sealing ensures the high IP protection up to IP66.

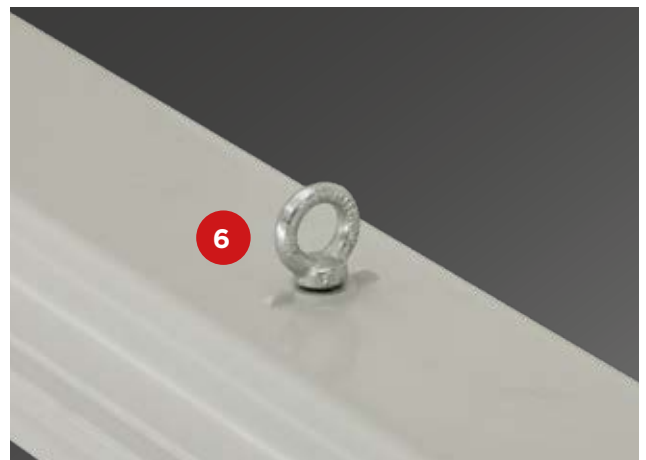
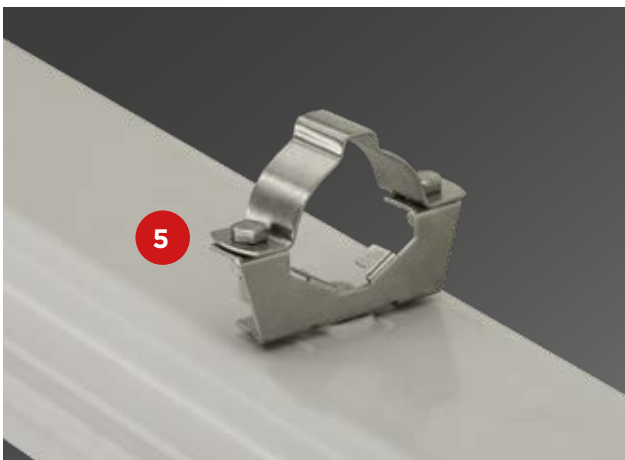
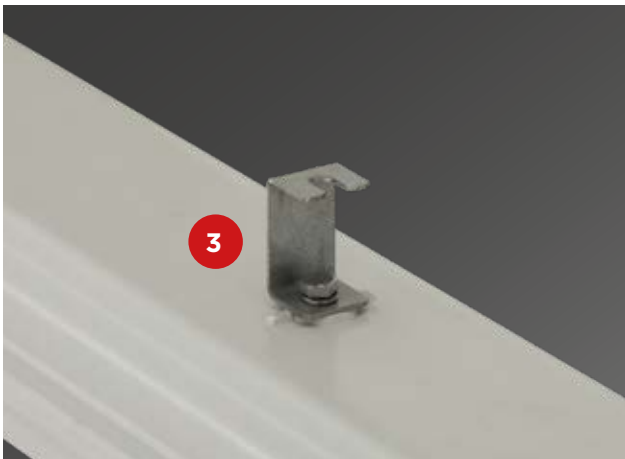

Ways of installing:

1. With galvanized **suspension brackets** distance to the ceiling **15mm**
2. With galvanized **suspension brackets** distance to the ceiling **40mm**
3. With galvanized **ceiling brackets C-shape**

4. With galvanized **mounting accessory for 45° angle**
5. With galvanized **pipe clamp**
6. With galvanized **eye bolt**

Powder-coated versions are available upon request.

Technical data (extract)

Products with a 5-year warranty	Power (W)	Luminare total luminous flux - emitted (lm) PC	Lum. efficacy (lm/W) PC	CRI	Lifetime L80B10 (Ta=55°C)	L80B10 (Ta=45°C) Lifetime L90B10 (Ta=55°C)	A (mm)	B (mm)	Weight (kg)	EEI
ATEX LED system - ZONE2 with ATEX Hadler driver ZONE 2 (CCT: 4000K, on request other CCTs are available)										
2ft (600mm)	18	2700	150	>80	> 102 000 h	> 75 000 h	670	400	2,4	C
4ft (1200mm)	19	2800	150	>80	> 102 000 h	> 75 000 h	1278	800	4,9	C
4ft (1200mm)	36	5500	152	>80	> 102 000 h	> 75 000 h	1278	800	4,9	C
4ft (1200mm)	44	6600	150	>80	> 102 000 h	> 75 000 h	1278	800	4,9	C



SAFE-EX

On request:



Schematic drawing with main dimensions

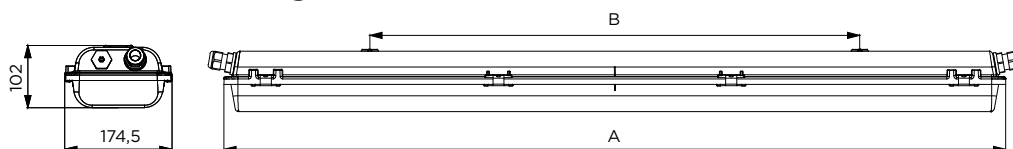

Photometric curves:

SAFE-EX, ATEX LED system - ZONE 2,
ATEX Hadler driver ZONE 2, 36W, 5500lm, PC

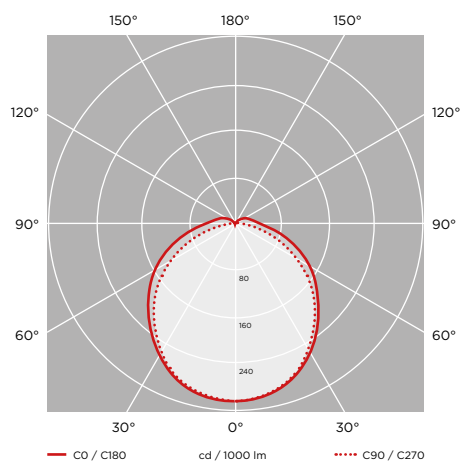

872-ENTRY GRP

Industrial dust and waterproof luminaires with LED modules

Trend-setting lighting in IP66 (option in IP67), quick installation. Specially developed for LED applications.



YOUR MAIN BENEFITS:

Size perfectly **adapted to LED**, easy to install, **slim design**

872-ENTRY GRP



IP66



Option:

IP67



FIELD OF APPLICATION:

Thanks to the construction principles of the gasket, the closing system and the diffuser our LED fixtures ensure a high grade of protection (IP66) against dust, contamination and water permeation. (Optionally available in IP67). In accordance with their IP rating they can be widely used to illuminate spaces with dusty and humid environment.

When using outdoors, the fittings should be protected against direct sunlight and adverse weather conditions. Under 0°C the application of a venting cable gland is necessary, as well as the silicone gasket is recommended.

TECHNICAL DESCRIPTION AND BENEFITS:

■ **Housing:** - Available in flame retardant **glass fibre reinforced polyester**, in light grey (RAL7035) colour (on request suitable for 850°C glow wire test, too). The glass fibre reinforced polyester has a very good temperature resistance and mechanical stability. Furthermore, it is a good electrical insulator resisting the impacts of several chemicals and weather conditions. Its stability of size and shape at changing temperatures is excellent.

■ **Diffuser:** Available in **PC** - injection moulded **opalised Polycarbonate** (high mechanical strength and high heat and shock resistance) or in **Acrylic** - injection moulded **opalised PMMA** (unique non-aging properties, high chemical resistance).

Further benefits:

- **Extremely high lighting efficiency** through high **light permeability, unique on the market**, up to 90%
- An **excellent light uniformity** through **well-balanced light dispersing** (no shadows)
- **Elimination of the dazzling effect** (no glare)
- **Keeping the usual, well known features of the diffuser** such as chemical and heat resistance, mechanical features, **UV stabilization** etc.
- **Universal width** (no single and twin) and slim **shape simplifies the light calculation**.

■ The **gasket** between the diffuser and housing is available in two versions:

- **Injected silicone foam**
- Non-aging **PU (polyurethane)** foam

■ **Fixing the diffuser to the body:** With tamper-proof (vandal-proof) stainless steel clips.

■ **Gear tray** (reflector): White powder coated steel sheet according to **Zhaga** standards or customised.

■ **Electrical components:** The adequate power supply is ensured through electronic driver, that is built into the luminaire.

Main technical options

Our **opalised** diffuser achieves an **outstanding light transmissivity of up to 90%**. With this great light permeability, it is an **excellent choice for luminaires equipped with LED-modules**.



Compact design for LED



In order to optimise the thermal management of the luminaire we avoid the direct contact of the gear tray and driver, thus increasing the lifetime of the modules and driver.

With 872-Entry GRP - depending on customer requirements - we can reach different levels of luminous flux (lumen) by keeping the **luminous efficacy above 160 lm/Watt**. Details see: Technical data.

The gear tray is made of white powder coated steel sheet according to **Zhaga** standards. On request customisation possible.

872-ENTRY GRP



The special **tamper-proof stainless steel clips** cannot be released with bare hands.

The **opal diffusers** are made of UV-stabilized material, specially **developed for LED** applications. This ensures among others a well-balanced light distribution and the **elimination of glare**.

The injected **silicone gasket** with enhanced resistance ensures **maximum** chemical and weather **resistance** even under tough conditions. Non-aging polyurethane foam is optionally available.



OPTIONS FOR CABLE ENTRY:

IP66 grommet

Cable gland

2 min
INSTALLATION TIME

The **Rapid Connector** enables the electrical connection **without disassembling** the luminaire, thus **avoiding** a potential damage of the LED's inside the luminaire through **electrostatic discharge (ESD)**.

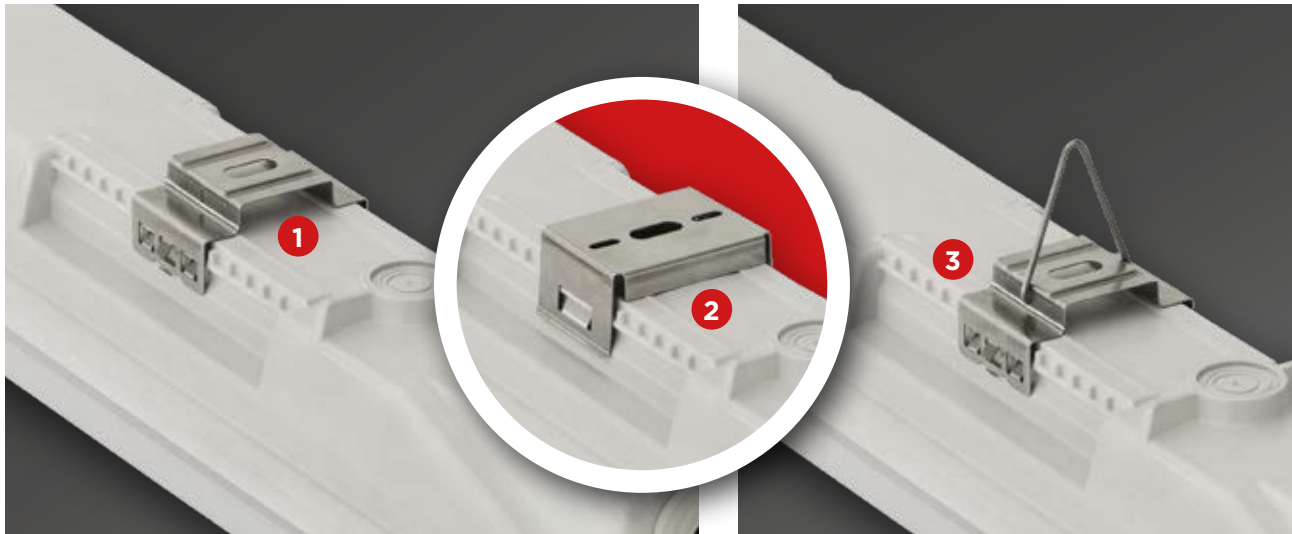

Ways of installing (options):

1. With **standard** (0,4 mm) stainless steel mounting brackets (easy-to-install) onto the **ceiling**.
2. With **strengthened** (0,6 mm) stainless steel mounting brackets. They are easy-to-install onto the **ceiling or the wall** (in horizontal position).
3. **Suspension** on chains, wire ropes etc. with stainless steel mounting brackets and **with hooks**.

The mounting brackets can be positioned with lateral flexibility for easy installation.

Technical data (extract)

Products with a 3-year or optionally with a 5-year warranty	Power (W)	Luminaire total luminous flux - emitted (lm) PC or PMMA	Lum. efficacy (lm/W) PC or PMMA	CRI	Lifetime L70B50 (Ta=35°C)	Lifetime L80B10 (Ta=35°C)	A (mm)	B (mm)	Weight (kg)	EEI
Lumnium EU with a DIP switch driver (CCT: 4000K, on request other CCTs are available)										
872 2ft (600mm)	19/24	2800/3400	142	>80	> 72 000 h	> 72 000 h	605	238±23	0,9	D
872 4ft (1200mm)	21/25/29/35	3200/3900/4400/5100	145	>80	> 72 000 h	> 72 000 h	1185	700±78	1,5	D
872 5ft (1500mm)	24/31/37/44	3900/4800/5600/6400	145	>80	> 72 000 h	> 72 000 h	1477	1000±78	1,8	D
872 4ft (1200mm)	21/27/32/38	3400/4200/4900/5500	145	>80	> 72 000 h	> 72 000 h	1185	700±78	1,5	D
872 5ft (1500mm)	28/36/43/51	4600/5600/6400/7400	145	>80	> 72 000 h	> 72 000 h	1477	1000±78	1,8	D
Lumnium EU PRO with a DIP switch driver (CCT: 4000K, on request other CCTs are available)										
872 4ft (1200mm)	20/25/31/36	3500/4200/5100/5800	160	>80	> 102 000 h	> 102 000 h	1185	700±78	1,5	C
872 5ft (1500mm)	21/26/32/37	3600/4500/5300/6100	165	>80	> 102 000 h	> 102 000 h	1477	1000±78	1,8	C
872 4ft (1200mm)	18/23/27/32	3200/3900/4600/5400	170	>80	> 102 000 h	> 102 000 h	1185	700±78	1,5	C
872 5ft (1500mm)	25/30/36/43	4300/5400/6400/7400	170	>80	> 102 000 h	> 102 000 h	1477	1000±78	1,8	C



872-ENTRY GRP

Further options:



On request:



Schematic drawing with main dimensions

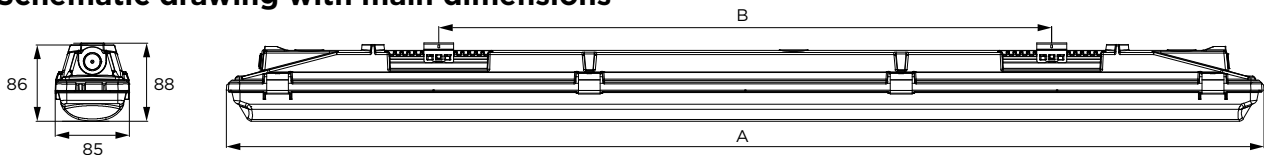

Photometric curves:

872-Entry GRP, 4ft (1200mm), Lumnium EU, 36W, 5300lm, PMMA

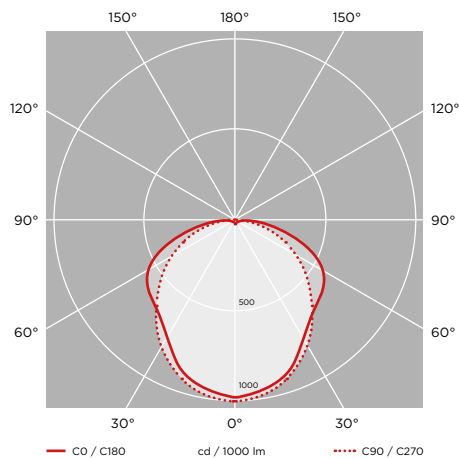

872-Entry GRP, 5ft (1500mm), Lumnium EU PRO, 41W, 6800lm, PMMA

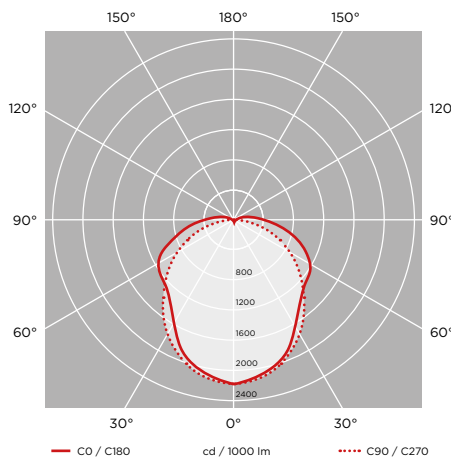

Luminaire customisation and the options of advanced controls are presented on page 5

LED

872-ENTRY PC

Industrial dust and waterproof luminaires with LED modules

Trend-setting lighting in IP66 (option in IP67), quick installation. Specially developed for LED applications.

CE**11**

YOUR MAIN BENEFITS:

Size perfectly **adapted to LED**, easy to install, **slim design**

872-ENTRY PC

PC	PC
PC	PMMA

IP66

Option:

IP67

FIELD OF APPLICATION:

Thanks to the construction principles of gasket, closing system and diffuser our LED fixtures ensure a high grade of protection (IP66) against dust, contamination and water permeation. (Optionally available in IP67). In accordance with their IP rating they can be widely used to illuminate spaces with dusty and humid environment. Thanks to its **enhanced impact resistance**, 872-Entry PC is especially suitable for applications, where a **high IK impact rating** is required.

When using outdoors, the fittings should be protected against direct sunlight and adverse weather conditions. Under 0°C the application of venting cable gland is necessary, as well as the silicone gasket is recommended.

TECHNICAL DESCRIPTION AND BENEFITS:

■ **Housing:** It is made of flame retardant **injection moulded Polycarbonate (PC)** in light grey (RAL7035) colour (suitable for 850°C glow wire test too). Polycarbonate has very high mechanical strength and allows us to reach an excellent shock resistance.

■ **Diffuser: Available in PC** - injection moulded **opalised Polycarbonate** (high mechanical strength and high heat and shock resistance - IK08). As option, injection moulded acrylic (PMMA) diffuser in opal version is available.

Further benefits:

- **Extremely high lighting efficiency** through high **light permeability, unique on the market**, up to 90%
- An **excellent light uniformity** through **well-balanced light dispersing** (no shadows)
- **Elimination of the dazzling effect** (no glare)
- **Keeping the usual, well known features of the diffuser** such as chemical and heat resistance, mechanical features, **UV stabilization** etc.
- **Universal width** (no single and twin) and slim **shape simplifies the light calculation**.

■ The **gasket** between the diffuser and housing is available in two versions:

- **Injected endless silicone foam**
- **Non-aging PU** (polyurethane) **endless foam**

■ **Fixing the diffuser to the body:** With tamper-proof (vandal-proof) stainless steel clips.

■ **Gear tray** (reflector): White powder coated steel sheet according to **Zhaga** standards or customised.

■ **Electrical components:** The adequate power supply is ensured with the electronic driver, that is built into the luminaire.

Main technical options

Our **opalised** diffuser achieves an **outstanding light transmissivity of up to 90%**. With this great light permeability, it is an **excellent choice for luminaires equipped with LED-modules**.



Compact design for LED

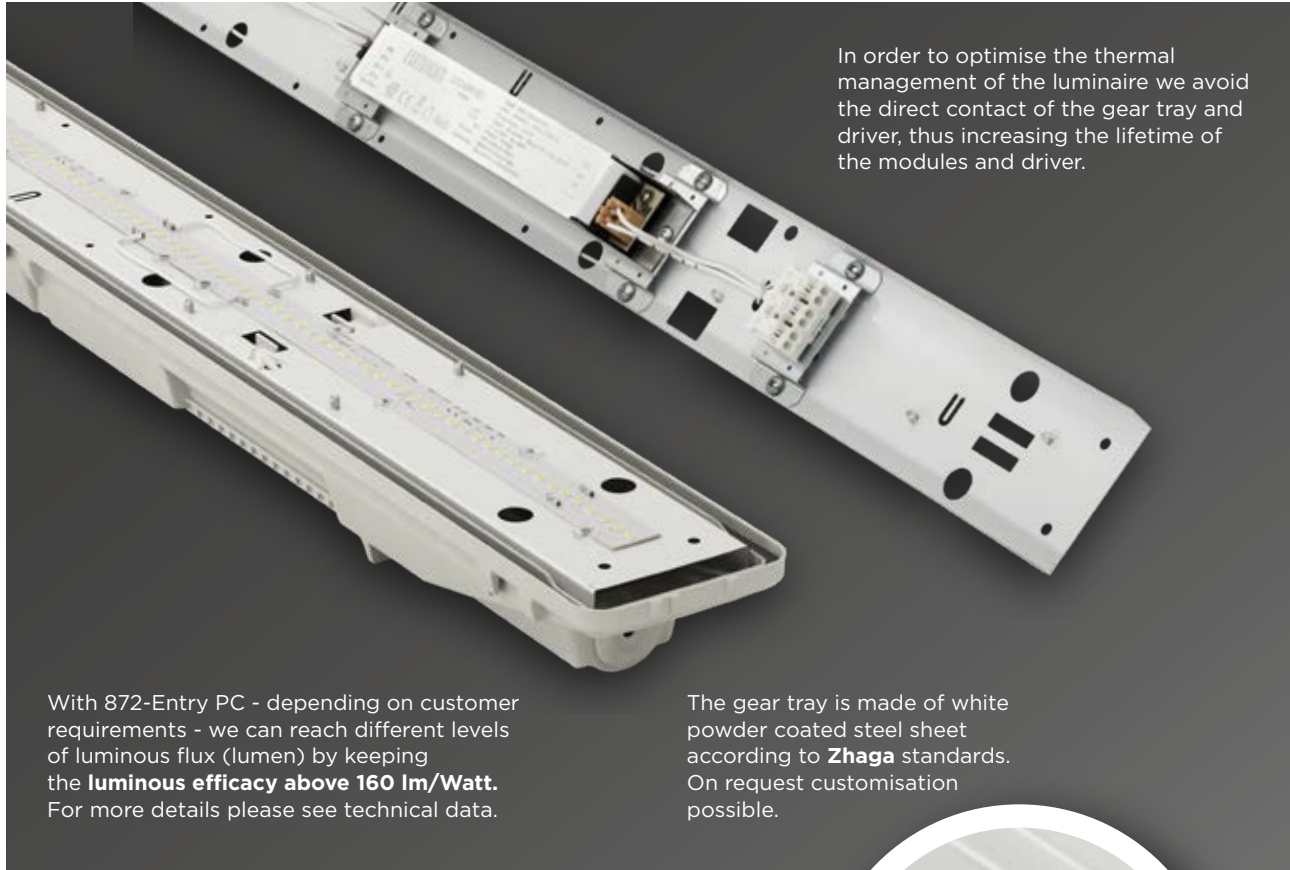

In order to optimise the thermal management of the luminaire we avoid the direct contact of the gear tray and driver, thus increasing the lifetime of the modules and driver.

With 872-Entry PC - depending on customer requirements - we can reach different levels of luminous flux (lumen) by keeping the **luminous efficacy above 160 lm/Watt**. For more details please see technical data.

The gear tray is made of white powder coated steel sheet according to **Zhaga** standards. On request customisation possible.

872-ENTRY PC



The special **tamper-proof stainless steel clips** cannot be released with bare hands.

The **opal diffusers** are made of UV-stabilized material, specially **developed for LED** applications. This ensures among others a well-balanced light distribution and the **elimination of glare**.

The injected **silicone gasket** with enhanced resistance ensures **maximum** chemical and weather **resistance** even under tough conditions. Non-aging polyurethane foam is optionally available.



OPTIONS FOR CABLE ENTRY:

IP66 grommet

Cable gland



The **Rapid Connector** enables the electrical connection **without disassembling** the luminaire, thus **avoiding** a potential damage of the LED's inside the luminaire through **electrostatic discharge (ESD)**.

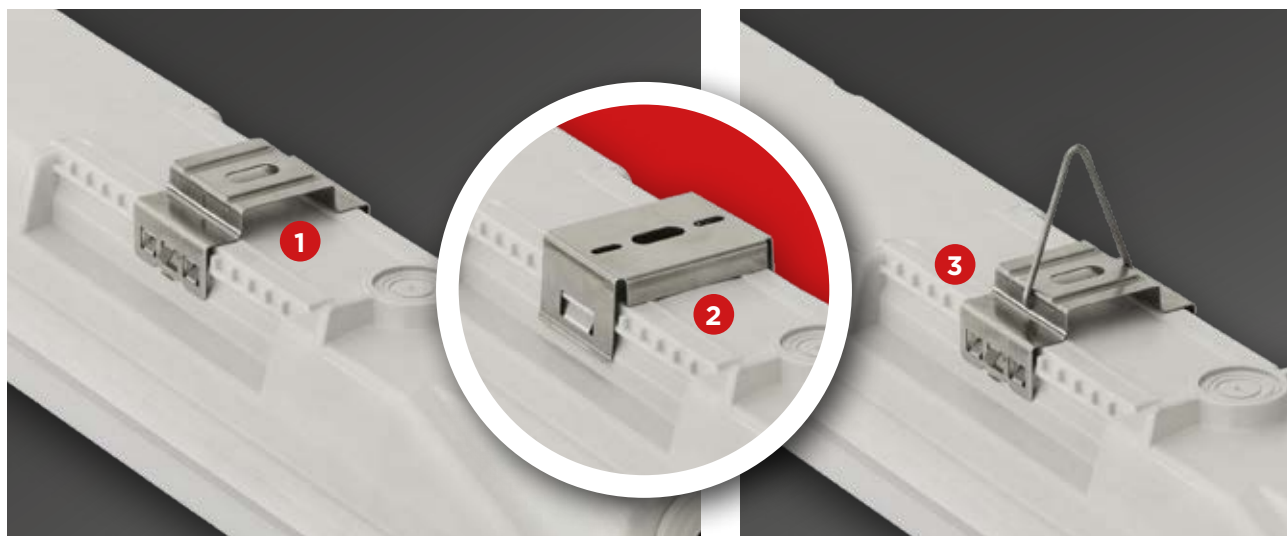

Ways of installing (options):

1. With **standard** (0,4 mm) stainless steel mounting brackets (easy-to-install) onto the **ceiling**.
2. With **strengthened** (0,6 mm) stainless steel mounting brackets. They are easy-to-install onto the **ceiling or the wall** (in horizontal position).
3. **Suspension** on chains, wire ropes etc. with stainless steel mounting brackets and **with hooks**.

The mounting brackets can be positioned with lateral flexibility for easy installation.

Technical data (extract)

Products with a 3-year or optionally with a 5-year warranty	Power (W)	Luminare total luminous flux - emitted (lm) PC or PMMA	Lum. efficacy (lm/W) PC or PMMA	CRI	Lifetime L70B50 (Ta=35°C)	Lifetime L80B10 (Ta=35°C)	A (mm)	B (mm)	Weight (kg)	EEI
Lumnium EU with a DIP switch driver (CCT: 4000K, on request other CCTs are available)										
872 4ft (1200mm)	21/25/29/35	3200/3900/4400/5100	145	>80	> 72 000 h	> 72 000 h	1180	700±78	1,5	D
872 5ft (1500mm)	24/31/37/44	3900/4800/5600/6400	145	>80	> 72 000 h	> 72 000 h	1480	1000±78	1,8	D
872 4ft (1200mm)	21/27/32/38	3400/4200/4900/5500	145	>80	> 72 000 h	> 72 000 h	1180	700±78	1,5	D
872 5ft (1500mm)	28/36/43/51	4600/5600/6400/7400	145	>80	> 72 000 h	> 72 000 h	1480	1000±78	1,8	D
Lumnium EU PRO with a DIP switch driver (CCT: 4000K, on request other CCTs are available)										
872 4ft (1200mm)	20/25/31/36	3500/4200/5100/5800	160	>80	> 102 000 h	> 102 000 h	1180	700±78	1,5	C
872 5ft (1500mm)	21/26/32/37	3600/4500/5300/6100	165	>80	> 102 000 h	> 102 000 h	1480	1000±78	1,8	C
872 4ft (1200mm)	18/23/27/32	3200/3900/4600/5400	170	>80	> 102 000 h	> 102 000 h	1180	700±78	1,5	C
872 5ft (1500mm)	25/30/36/43	4300/5400/6400/7400	170	>80	> 102 000 h	> 102 000 h	1480	1000±78	1,8	C



872-ENTRY PC

Further options:



On request:



Schematic drawing with main dimensions

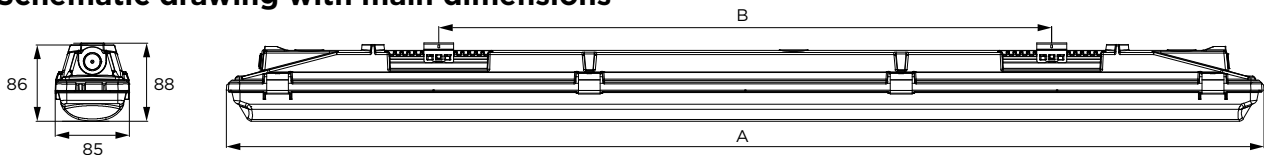

Photometric curves:

872-Entry PC, 4ft (1200mm), Lumnium EU, 36W, 5300lm, PC

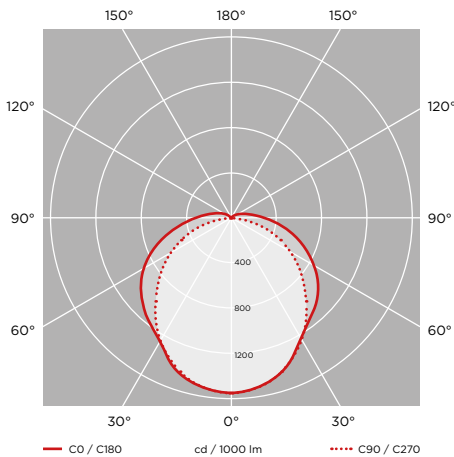

872-Entry PC, 5ft (1500mm), Lumnium EU PRO, 41W, 6800lm, PC

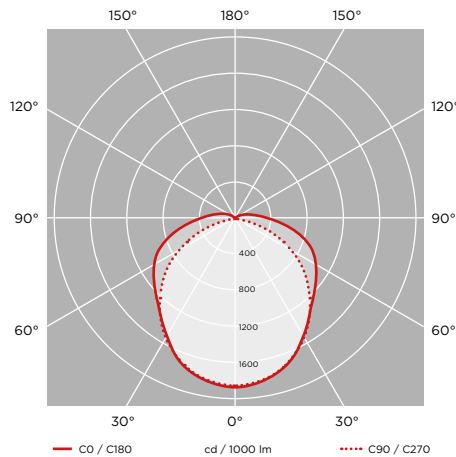

Luminaire customisation and the options of advanced controls are presented on page 5

872-ENTRY NB

Industrial dust and waterproof luminaires with LED modules and with narrow beam optics

Trend-setting lighting in IP66 (option in IP67), quick installation. Specially developed for LED applications.

YOUR MAIN BENEFITS:

Narrow beam luminaire, suitable for high ceilings, with a transparent diffuser and narrow beam optics. Alternative to high bay fixtures, in a more cost-effective performance.



872-ENTRY NB



IP66



Option:

IP67



1F

3F



PC
850°C



FIELD OF APPLICATION:

Thanks to the construction principles of the gasket, the closing system and the diffuser our LED fixtures ensure a high grade of protection (IP66) against dust, contamination and water permeation. (Optionally available in IP67). In accordance with their IP rating they can be widely used to illuminate spaces with dusty and humid environment. When using outdoors, the fittings should be protected against direct sunlight and adverse weather conditions. Under 0°C the application of venting cable gland is necessary, as well as the silicone gasket is recommended.

TECHNICAL DESCRIPTION AND BENEFITS:

- **Housing available:** in flame retardant **glass fibre reinforced polyester**, in light grey (RAL7035) colour (on request suitable for 850°C glow wire test, too). The glass fibre reinforced polyester has a very good temperature resistance and mechanical stability. Furthermore, it is a good electrical insulator resisting the impacts of several chemicals and weather conditions. Its stability of size and shape at changing temperatures is excellent.
 - **Or in PC** - injection moulded **Polycarbonate** in light grey (RAL7035) colour (suitable for 850°C glow wire test, too). Polycarbonate has high mechanical strength and high heat and shock resistance

- **Diffuser: Available in PC** - injection moulded **transparent Polycarbonate** (high mechanical strength and high heat and shock resistance) or **in Acrylic** - injection moulded **transparent PMMA** (unique non-aging properties, high chemical resistance).

Further benefits:

- **Extremely high lighting efficiency** through high **light permeability, unique on the market**, up to 90%
- An **excellent light uniformity** through **well-balanced light dispersing** (no shadows)
- **Elimination of the dazzling effect** (no glare)
- **Keeping the usual, well known features of the diffuser** such as chemical and heat resistance, mechanical features, **UV stabilization** etc.
- **Universal width** (no single and twin) and slim **shape simplifies the light calculation.**
- The **gasket** between the diffuser and housing is available in two versions:
 - **Injected silicone-based endless foam**
 - **Non-aging PU (polyurethane) endless foam**
- **Fixing the diffuser to the body:** With tamper-proof (vandal-proof) stainless steel clips.
- **Gear tray (reflector):** White powder coated steel sheet according to **Zhaga** standards or customised.
- **Electrical components:** The adequate power supply is ensured with the electronic driver, that is built into the luminaire.

Main technical options

Our **transparent** diffuser achieves an **outstanding light transmissivity of up to 93%**. With this great light permeability, it is **an excellent choice for luminaires equipped with LED-modules**.



Narrow beam optics



872-ENTRY NB



In order to optimise the thermal management of the luminaire we avoid the direct contact of the gear tray and driver, thus increasing the lifetime of the modules and driver.

With 872-Entry NB - depending on customer requirements - we can reach different levels of luminous flux (lumen). Details see: Technical data.

The gear tray is made of white powder coated steel sheet according to **Zhaga** standards. On request customisation possible.



The special **tamper-proof stainless steel clips** cannot be released with bare hands.

The **transparent diffusers** are made of UV-stabilized material, specially **developed for LED** applications.

The injected **silicone gasket** with enhanced resistance ensures **maximum** chemical and weather **resistance** even under tough conditions. Non-aging polyurethane foam is optionally available.

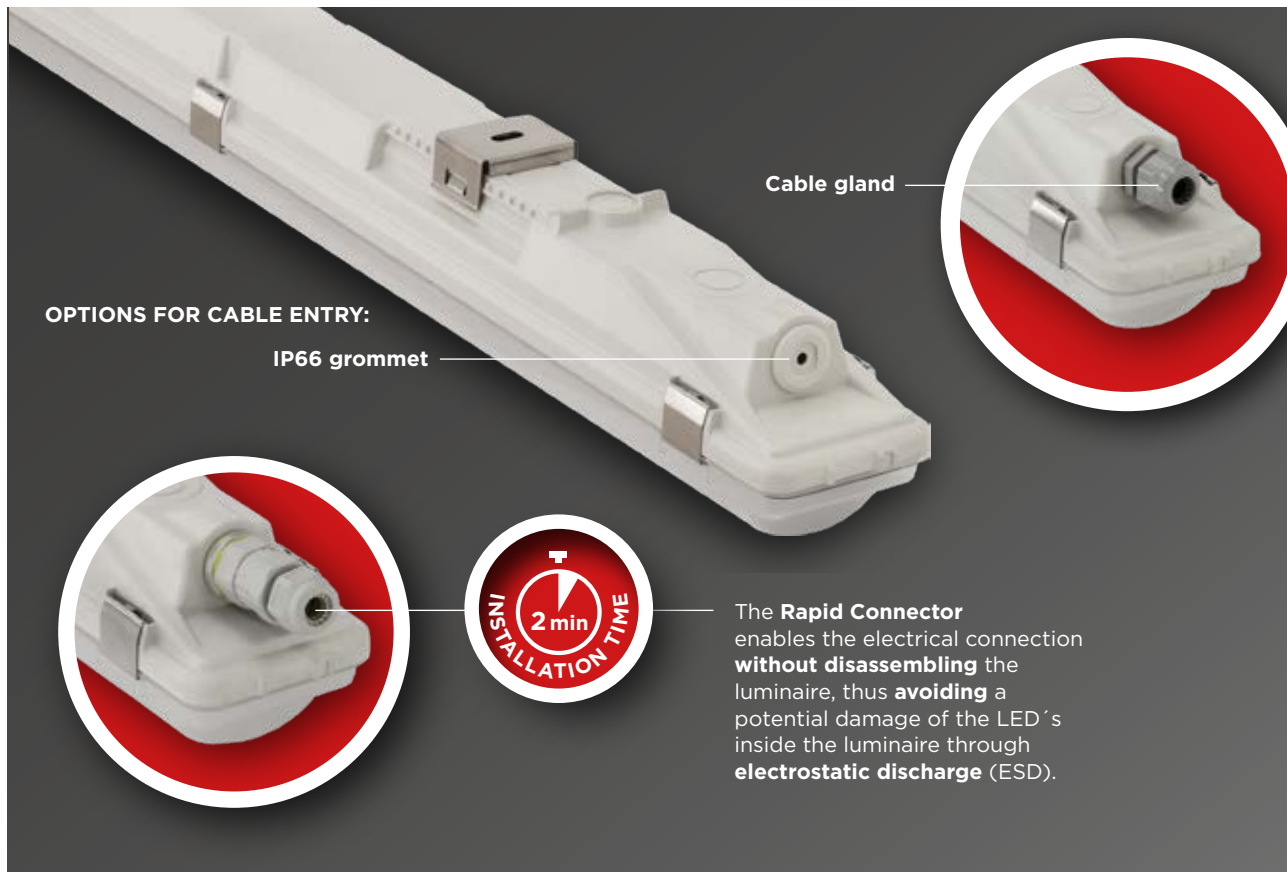

OPTIONS FOR CABLE ENTRY:

IP66 grommet

Cable gland



The **Rapid Connector** enables the electrical connection **without disassembling** the luminaire, thus **avoiding** a potential damage of the LED's inside the luminaire through **electrostatic discharge (ESD)**.

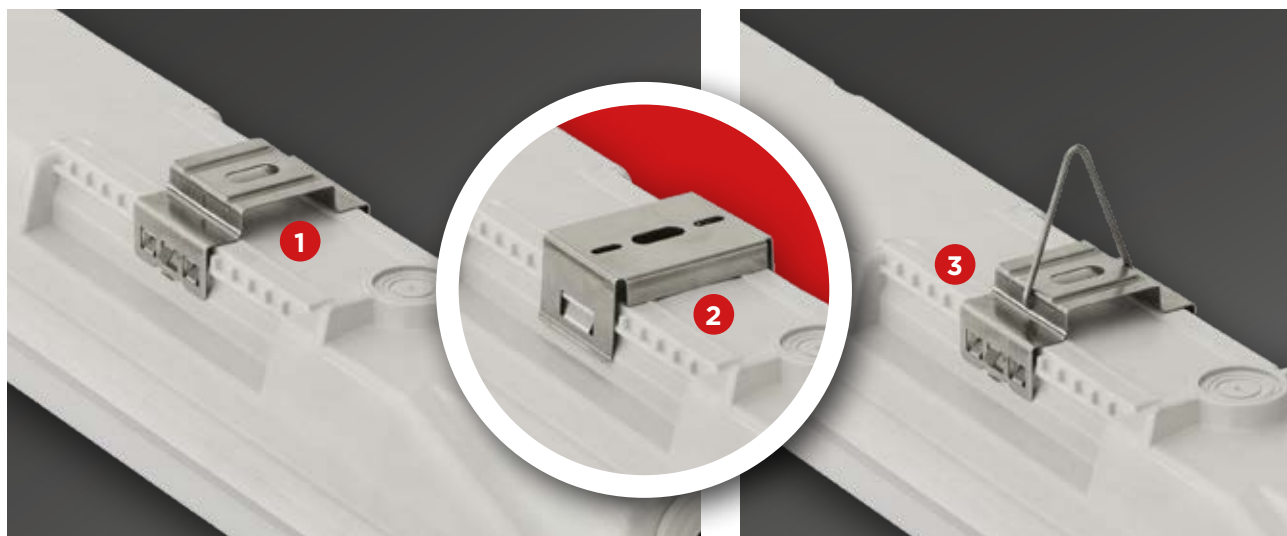

Ways of installing (options):

1. With **standard** (0,4 mm) stainless steel mounting brackets (easy-to-install) onto the **ceiling**.
2. With **strengthened** (0,6 mm) stainless steel mounting brackets. They are easy-to-install onto the **ceiling or the wall** (in horizontal position).
3. **Suspension** on chains, wire ropes etc. with stainless steel mounting brackets and **with hooks**.

The mounting brackets can be positioned with lateral flexibility for easy installation.

Technical data (extract)

Products with a 3-year or optionally with a 5-year warranty	Power (W)	Luminaire total luminous flux - emitted (lm) PC or PMMA	Lum. efficacy (lm/W) PC or PMMA	CRI	Lifetime L70B50 (Ta=35°C)	Lifetime L80B10 (Ta=35°C)	A (mm)	B (mm)	Weight (kg)	EEL
---	-----------	---	---------------------------------	-----	---------------------------	---------------------------	--------	--------	-------------	-----

Lumnium EU with a DIP switch driver (CCT: 4000K, on request other CCTs are available)

872 4ft (1200mm)	21/27/32/38	3400/4200/4900/5500	145	>80	> 72 000 h*	> 72 000 h*	1185	700±78	1,5	D
872 5ft (1500mm)	28/36/43/51	4600/5600/6400/7400	145	>80	> 72 000 h*	> 72 000 h*	1477	1000±78	1,8	D

Lumnium EU PRO with a DIP switch driver (CCT: 4000K, on request other CCTs are available)

872 4ft (1200mm)	18/23/27/32	3200/3900/4600/5400	170	>80	> 102 000 h	> 102 000 h	1185	700±78	1,5	C
872 5ft (1500mm)	25/30/36/43	4300/5400/6400/7400	170	>80	> 102 000 h	> 102 000 h	1477	1000±78	1,8	C

* The application of through-wiring may influence the Ta. Max.



Further options:



On request:



Schematic drawing with main dimensions

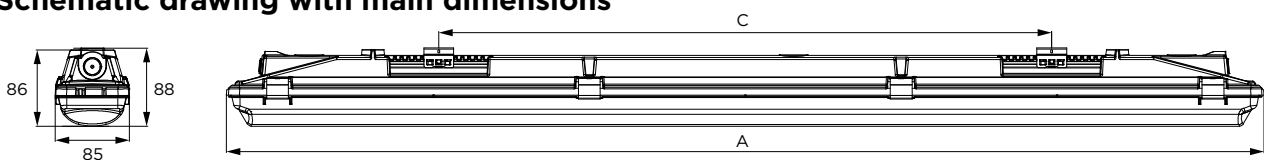

Photometric curves:

872-Entry NB, 5ft (1500mm), Lumnium EU, 50W, 7000lm, PMMA

With the use of transparent diffuser a 40° narrow beam radiation angle is achievable for high bay applications.

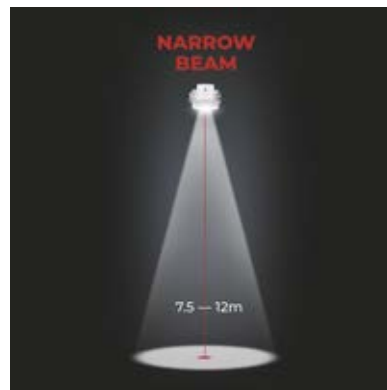
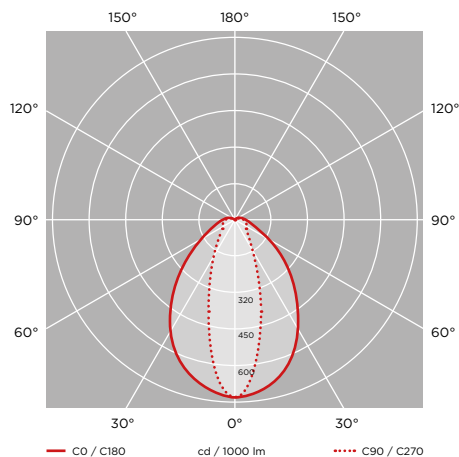

Luminaire customisation and the options of advanced controls are presented on page 5



792-XSLIDE

Industrial dust and waterproof luminaires with LED modules

YOUR MAIN BENEFITS:

Comfortable and **quick installation** without disassembling the luminaire

Extruded profile with **outstanding light transmissivity**

Slender design and clean impression, specially developed for LED applications

Glued end caps with **pull-out (sliding) tray** for easy connection

Economical and **cost-efficient**

CE



792-XSLIDE

FIELD OF APPLICATION:

Thanks to the construction principles of the gasket, the end caps and the extruded profile, our LED fixtures ensure a high grade of protection (IP 65) against dust, contamination and water permeation. In accordance with their IP grade they can be widely used to illuminate spaces with dusty, humid environment.

When using outdoors, the fittings should be protected against direct sunlight and adverse weather conditions.

TECHNICAL DESCRIPTION AND BENEFITS:

- **Housing:** Made of **Polycarbonate (PC)** by **co-extrusion**. The housing is made in light grey (RAL7035) colour. The diffusing (upper) part is opalised. Thanks to the used raw material the whole fitting shows very high mechanical strength and **high heat and shock resistance (IK08)**.
- The **co-extruded opal** diffuser offers you:
 - **extremely high light transmissivity** (up to 90%) **unique on the market**
 - **homogenous, well-balanced light dispersing** (no shadows)
 - **elimination of the dazzling effect** (no glare)
 - **unique appearance** and **clean impression** (**no clips, no dots** of the single LED´s)
 - **keeping the usual, well-known features of the diffuser** such as chemical and heat resistance, mechanical features, **UV stabilization** etc.
- **End caps:** Made of extremely resistant polyamide and glued to the housing.
- **Gear tray** (reflector): White powder coated steel sheet according to **Zhaga** standards or customized.
- **Electrical components:** The adequate power supply is ensured through electronic driver, that is built into the luminaire.

IP65

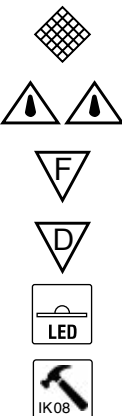

Option:

IP66



Main technical options

The gear tray is made of white powder coated steel sheet according to **Zhaga** standards.



The diffusing part of the profile is made of UV stabilized **opalised** material, specially developed for LED applications. This ensures among others a well-balanced light distribution and the **elimination of glare**.

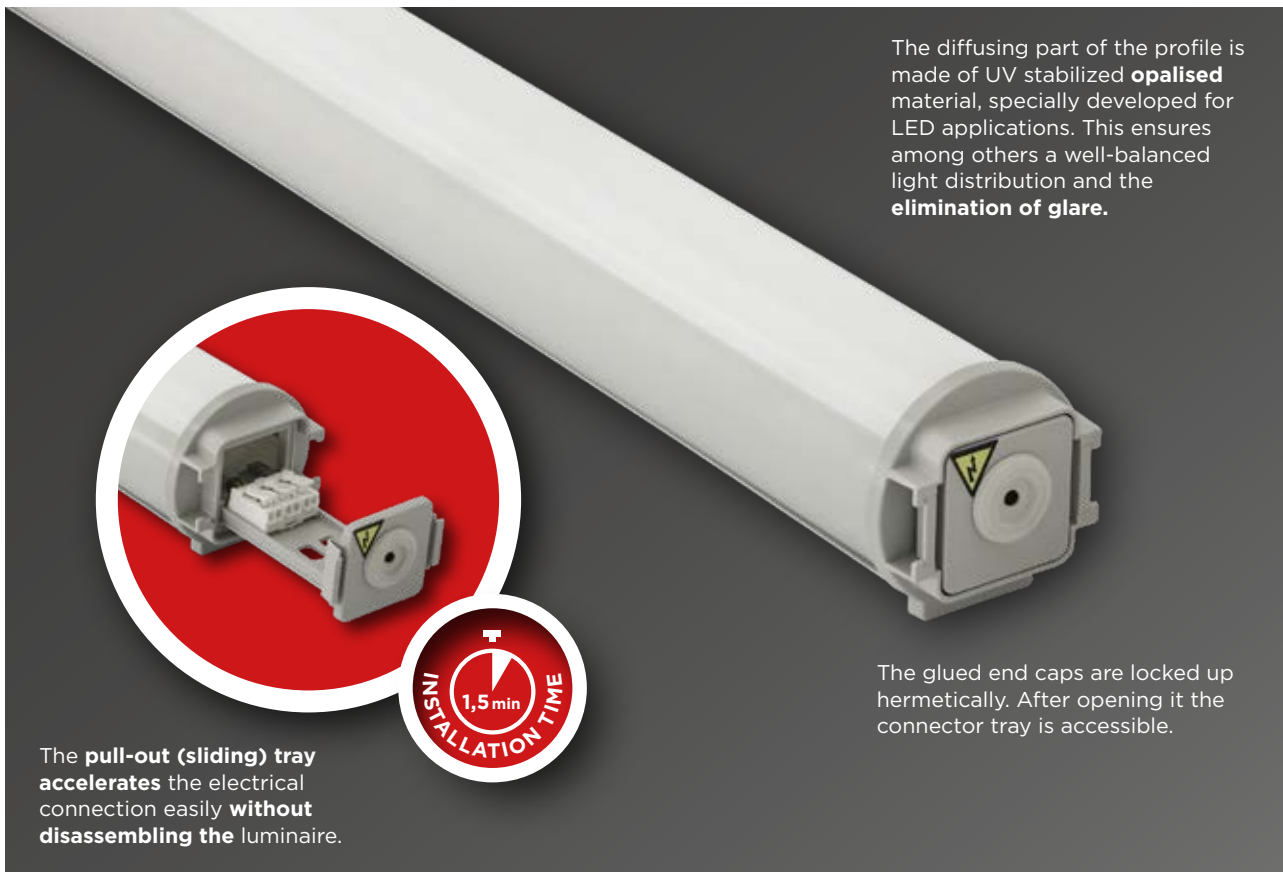

The **pull-out (sliding) tray accelerates** the electrical connection easily **without disassembling** the luminaire.



The glued end caps are locked up hermetically. After opening it the connector tray is accessible.



IP 65 protection is ensured by adhesive that secures the end caps to the body.

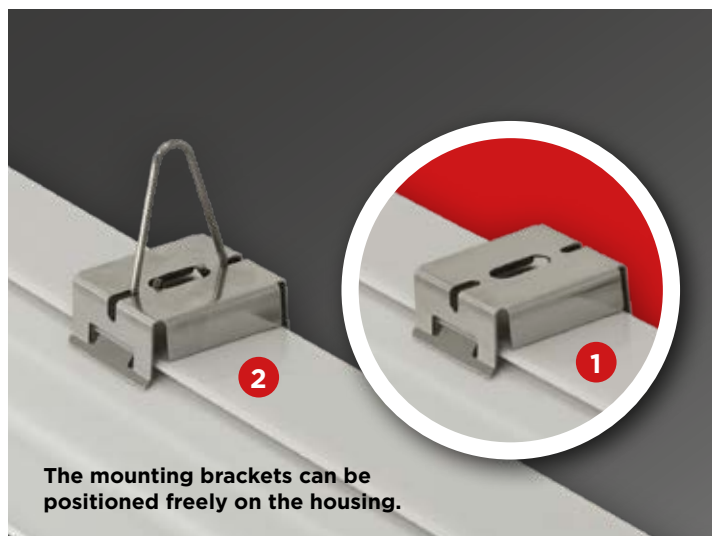

The mounting brackets can be positioned freely on the housing.

Ways of installing:

1. With **strengthened** stainless steel mounting brackets. They are easy to install onto the wall or ceiling.
2. **Suspension on chains or rope** with stainless steel suspension brackets mounted with **hooks**.

Technical data (extract)



Products with a 3-year or optionally with a 5-year warranty	Power (W)	Luminare total luminous flux emitted (lm) PC	Lum. efficacy (lm/W) PC	CRI	Lifetime L70B50 (Ta=35°C)	Lifetime L80B10 (Ta=35°C)	A (mm)	B (mm)	Weight (kg)	EEL
Lumnium EU (CCT: 4000K, on request other CCTs are available)										
792 2ft (600mm)	24	3100	129	>80	>72 000 h	>72 000 h	610	230	0,91	D
792 4ft (1200mm)	25	3300	132	>80	>72 000 h	>72 000 h	1180	860	1,49	D
792 5ft (1500mm)	30	4100	136	>80	>72 000 h	>72 000 h	1480	1160	1,79	D
792 4ft (1200mm)	38	4900	128	>80	>72 000 h	>72 000 h	1180	860	1,49	D
792 5ft (1500mm)	50	6500	130	>80	>72 000 h	>72 000 h	1480	1160	1,79	D
Lumnium EU PRO (CCT: 4000K, on request other CCTs are available)										
792 4ft (1200mm)	22	3200	145	>80	>102 000 h	>102 000 h	1180	860	1,49	C
792 5ft (1500mm)	27	4000	148	>80	>102 000 h	>102 000 h	1480	1160	1,79	C
792 4ft (1200mm)	31	4700	151	>80	>102 000 h	>102 000 h	1180	860	1,49	C
792 5ft (1500mm)	41	6400	156	>80	>102 000 h	>102 000 h	1480	1160	1,79	C

792-XSLIDE

Further options:

On request:



Schematic drawing with main dimensions

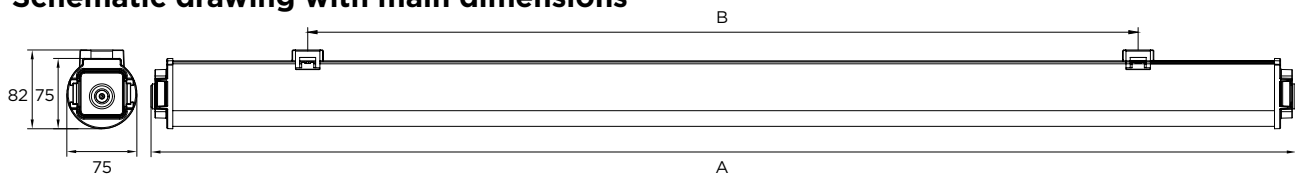

Photometric curves:

792-XSlide, 5ft (1500mm),
Lumnium EU, 50W, 6500lm, PC

792-XSlide, 4ft (1200mm),
Lumnium EU PRO, 38W, 4900lm, PC

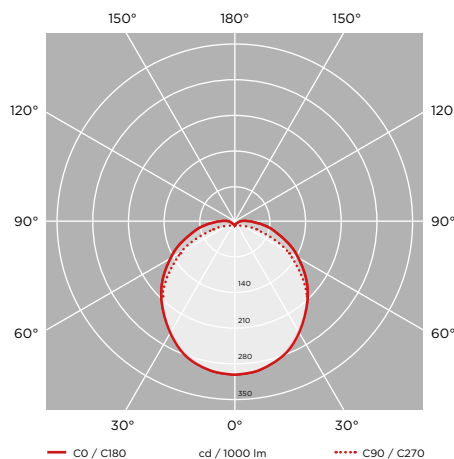
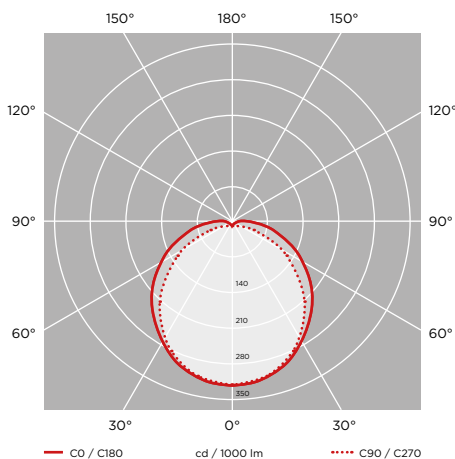

Luminaire customisation and the options of advanced controls are presented on page 5

LED

RETROFIT LED 771-PRO LT

Industrial dust and waterproof luminaires
With 1 and 2 LED tubes.

CE

YOUR MAIN BENEFITS:

This product family has been **designed for energy efficient LED tubes**.
Full range available in IP65 and IP66.



GRP
PC

GPR
PMMA

RETROFIT LED
771-PRO LT

IP65



Option:

IP66



FIELD OF APPLICATION:

Thanks to the construction principles of the gasket, the closing system and the diffuser our fixtures ensure a high grade of protection (IP65, IP66) against dust, contamination and water permeation. In accordance with their IP grade they can be widely used to illuminate spaces with dusty and humid environment.

When using outdoors, the fittings should be protected against direct sunlight and adverse weather conditions. Under 0°C the application of a venting cable gland is necessary, as well as the silicone gasket is recommended.

TECHNICAL DESCRIPTION AND BENEFITS:

■ **Housing:** It is made of flame retardant glass fibre reinforced polyester (**GRP**) – on request suitable for 850°C glow wire test too –, in light grey (RAL7035) colour. The glass fibre reinforced polyester has very good temperature resistance, mechanical stability. Furthermore, it is a good electrical insulator resisting the impacts of several chemicals and weather conditions. Its stability of size and shape at changing temperatures is excellent.

■ The **diffuser** is available in the following versions:

Injection moulded acrylic (PMMA):

transparent, with longitudinal prisms, designed with respect to their optical characteristics.

Main advantages of PMMA: very good transparency (better than the transparency of glass), unique nonaging properties, **high chemical** and **UV-resistance**.

Injection moulded polycarbonate (PC):

transparent, with longitudinal internal prisms, designed with respect to their optical characteristics.

Main advantages of PC: **high mechanical strength** and **high heat and shock resistance**.

■ **The gasket** between the diffuser and housing is made of non-aging PU (polyurethane) foam. Silicone foam with enhanced resistance is optionally available.

■ **Fixing the diffuser to the body:** with stainless steel clips.

■ **Gear tray** (reflector): white powder coated steel sheet.

■ **Way of installing:** with stainless steel mounting brackets (easy-to-install) onto the wall or ceiling or suspended.

■ **Electrical components:** The adequate power supply is ensured through electronic driver, that is built in into the LED tube.

Main technical options

LED

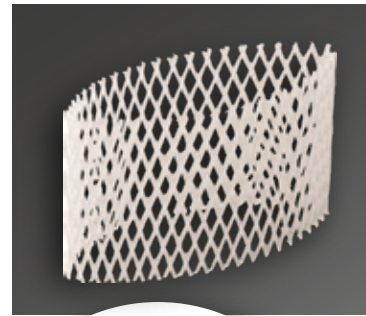

Optimised economical packaging with plastic net.



Retrofit LED 771-Pro LT has been designed for LED tubes.

The **transparent prismatic diffusers** are designed with respect to their optical characteristics and are UV resistant.



Fixing the diffuser to the body: with highly resistant stainless steel clips.

RETROFIT LED
771-PRO LT

Technical data (extract)

Type	Lampholder	Power (W)	Luminous flux (lm)	Dimensions A (mm)	C (mm)	Weight (kg)
771-Pro LT equipped with Retrofit LED tube (Philips Core Pro LED tube)						
771-Pro LT 1x600mm	T8/G13	1x8	680*	699	360	1,19
771-Pro LT 1x1200mm	T8/G13	1x14,5	1360*	1277	700	2,47
771-Pro LT 1x1500mm	T8/G13	1x20	1870*	1577	1000	2,57
771-Pro LT 2x600mm	T8/G13	2x8	1360*	699	360	2,31
771-Pro LT 2x1200mm	T8/G13	2x14,5	2720*	1277	700	3,35
771-Pro LT 2x1500mm	T8/G13	2x20	3740*	1577	1000	3,37

* The shown values are for reference only. The exact values depend on the LED tube applied.

Schematic drawing with main dimensions:

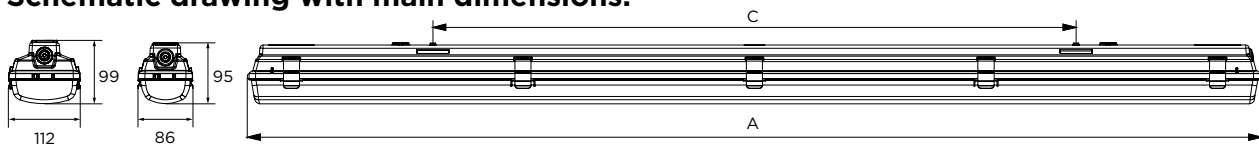

Photometric curves:

Retrofit LED 771-Pro LT,
(1x1200mm), 1x14,5W (LED tube)

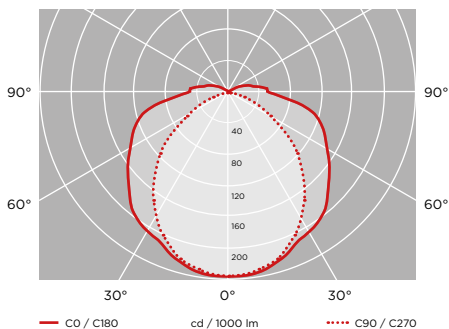

Retrofit LED 771-Pro LT,
(2x1500mm), 2x20W (LED tube)

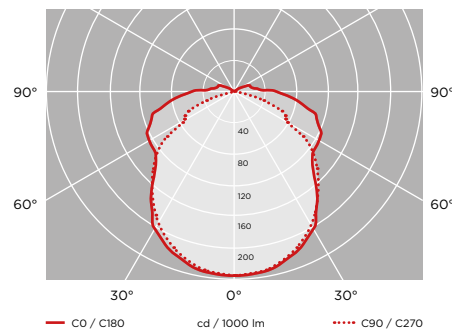

LED

RETROFIT LED 775-PRO LT

Industrial dust and waterproof luminaires
With 1 and 2 LED tubes.

CE

YOUR MAIN BENEFITS:

This product family has been **designed for energy efficient LED tubes**.
Full range available in IP65 and IP66.

RETROFIT LED
775-PRO LT

IP65



Option:

IP66



FIELD OF APPLICATION:

Thanks to the construction principals of the gasket, the closing system and the diffuser our fixtures ensure a high grade of protection (IP65, IP66) against dust, contamination and water permeation. In accordance with their IP grade they can be widely used to illuminate spaces with dusty and humid environment.

When using outdoors, the fittings should be protected against direct sunlight and adverse weather conditions. Under 0°C the application of a venting cable gland is necessary, as well as silicone gasket is strongly recommended.

TECHNICAL DESCRIPTION AND BENEFITS:

- **Housing:** It is made of flame retardant injection moulded polycarbonate (**PC**) – suitable for 850°C glow wire test too –, in light grey (RAL7035) colour. This material has very high mechanical strength and allows us to reach an excellent shock resistance.
- The **diffuser** is available in the following versions:
Injection moulded acrylic (PMMA):
transparent, with longitudinal prisms, designed with respect to their optical characteristics.
Main advantages of PMMA: very good transparency (better than the transparency of glass), unique nonaging properties, **high chemical** and **UV-resistance**.
Injection moulded polycarbonate (PC):
transparent, with longitudinal internal prisms, designed with respect to their optical characteristics.
Main advantages of PC: **high mechanical strength and high heat and shock resistance**.
- **The gasket** between the diffuser and housing is made of non-aging PU (polyurethane) foam. Silicone foam with enhanced resistance is optionally available.
- **Fixing the diffuser to the body:** with stainless steel clips.
- **Gear tray** (reflector): white powder coated steel sheet.
- **Way of installing:** with **stainless steel mounting brackets** (easy-to-install) onto the wall or ceiling or suspended.
- **Electrical components:** The adequate power supply is ensured through electronic driver, that is built in into the LED tube.

Main technical options



Optimised economical packaging with plastic net.



Retrofit LED 775-Pro LT has been designed for LED tubes.

The **transparent prismatic diffusers** are designed with respect to their optical characteristics and are UV resistant.



Fixing the diffuser to the body: with highly resistant stainless steel clips.



**RETROFIT LED
775-PRO LT**

Technical data (extract)

Type	Lampholder	Power (W)	Luminous flux (lm)	Dimensions A (mm)	C (mm)	Weight (kg)
775-Pro LT equipped with Retrofit LED tube (Philips Core Pro LED tube)						
775-Pro LT 1x600mm	T8/G13	1x8	680*	699	360	1,19
775-Pro LT 1x1200mm	T8/G13	1x14,5	1360*	1277	700	2,47
775-Pro LT 1x1500mm	T8/G13	1x20	1870*	1577	1000	2,57
775-Pro LT 2x600mm	T8/G13	2x8	1360*	699	360	2,31
775-Pro LT 2x1200mm	T8/G13	2x14,5	2720*	1277	700	3,35
775-Pro LT 2x1500mm	T8/G13	2x20	3740*	1577	1000	3,37

* The shown values are for reference only. The exact values depend on the LED tube applied.

Schematic drawing with main dimensions:

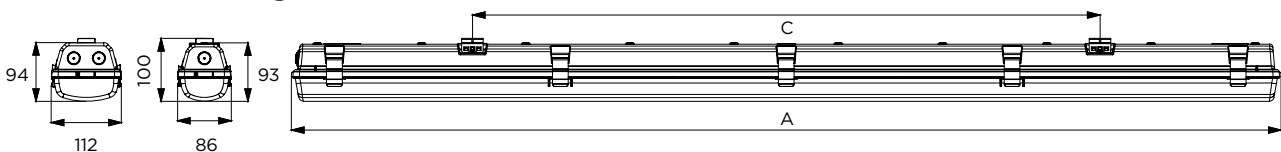

Photometric curves:

Retrofit LED 775-Pro LT,
(1x1200mm), 1x14,5W (LED tube)

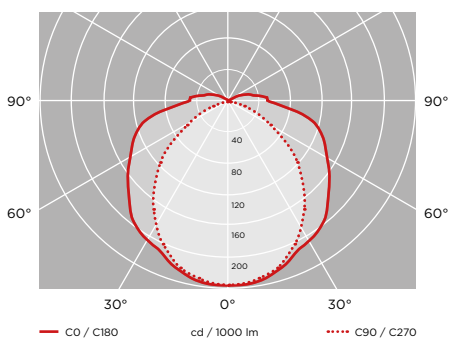

Retrofit LED 775-Pro LT,
(2x1500mm), 2x20W (LED tube)

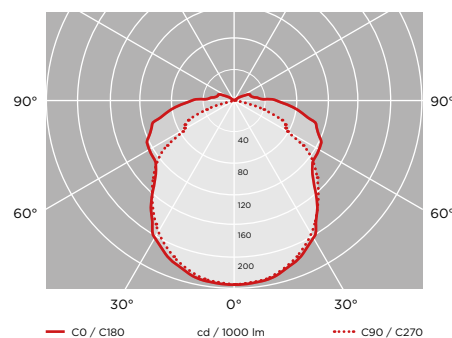

A large area of the page is filled with horizontal dotted lines, providing space for notes.

INTRODUCTION	2
OUR COMPETENCIES	3
ADVANCED OPTIONS	5
RESISTANCE TO CHEMICALS	8
WARRANTY	9
LED LUMINAIRES PORTFOLIO	11
CONTENTS	87
CONTACT US	88

CONTENTS

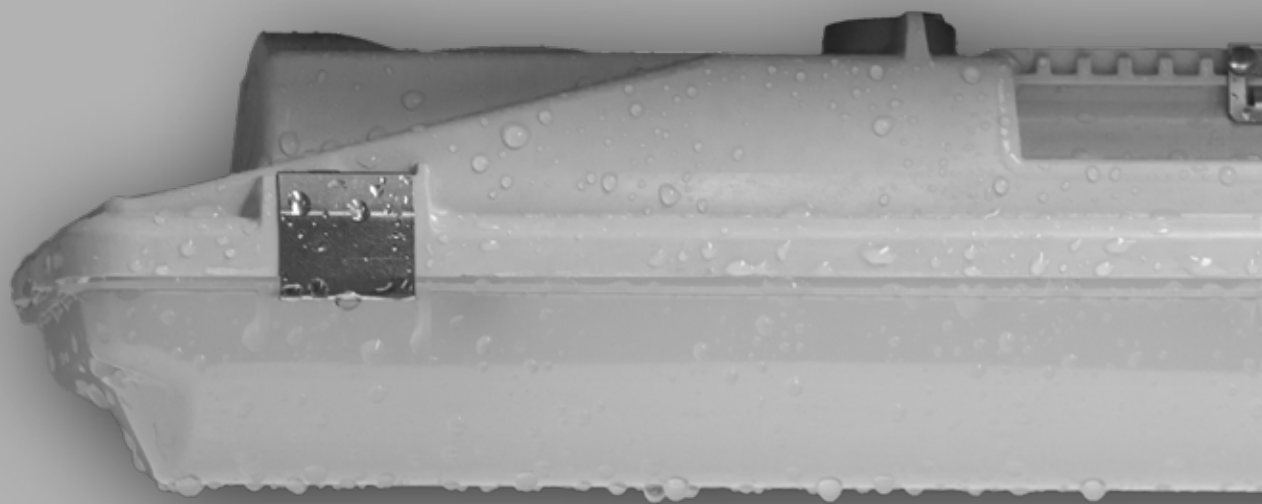

i | b IBV HUNGÁRIA
v Lighting and Plastic Processing

Light embodied

H-6100 Kiskunfélegyháza

Csanyi út 71.

HUNGARY

Tel.: +36 76 562 100

+36 70 463 2226

Fax: +36 76 562 170

E-mail: sales@ibv.hu

www.ibv.hu